

QMP 7.1 D/F



Channabasaveshwara Institute of Technology

(Affiliated to VTU, Belgaum & Recognized by A.I.C.T.E. New Delhi)

(NAAC Accredited & An ISO 9001:2015 Certified Institution)

NH 206, (B.H. Road), Gubbi, Tumkur – 572 216. Karnataka



Department of Mechanical Engineering

Hydraulics & Pneumatics Laboratory

BME702

B.E - VII Semester

Lab Manual 2025-26

Name: _____

USN : _____

Batch : _____ Section : _____



Channabasaveshwara Institute of Technology

(Affiliated to VTU, Belgaum & Recognized by A.I.C.T.E. New Delhi)

(NAAC Accredited & An ISO 9001:2015 Certified Institution)

NH 206, (B.H. Road), Gubbi, Tumkur – 572 216. Karnataka



Department of Mechanical Engineering

Hydraulics & Pneumatics Lab Manual

Prepared by:

Dr. Natesh C P
Assistant Professor

Mr. Tharunesh C
Lecturer

Approved by:

Dr. Giridhar S Kulkarni

Professor & Head, Dept. of ME



Channabasaveshwara Institute of Technology

(Affiliated to VTU, Belgaum & Recognized by A.I.C.T.E. New Delhi)
(NAAC Accredited & An ISO 9001:2015 Certified Institution)
 NH 206, (B.H. Road), Gubbi, Tumkur – 572 216. Karnataka



DEPARTMENT OF MECHANICAL ENGINEERING.

HYDRAULICS & PNEUMATICS LAB SYLLABUS

B.E, VII Semester, Mechanical Engineering [PRACTICAL COMPONENT OF IPCC]

Course Code	BME702	CIE Marks	50
Number of Lecture Hours/Week	02	SEE Marks	50
credits	04	Exam Hours	03

Course Objectives:

Conduct basic experiments of Hydraulics & Pneumatics and understand the experimental uncertainties.

Course outcomes:

- Perform basic experiments of Hydraulics & Pneumatics and understand the experimental uncertainties.**

Sl.NO	Experiments
1	A] Study of Construction and working Hydraulic pumps and Pneumatic B] Study of Hydraulic and Pneumatic valves. C] Study of solenoid valves, limit switches. Pressure, flow control valve.
2	Basic hydraulic circuit for the working of double acting cylinder and a hydraulic motor
3	Basic pneumatic circuit for the working of single and double acting cylinder.
4	Speed control circuits. Different Metering methods Inlet & outlet flow control (meter in & meter out circuit)
5	Circuits for the Use of different direction control valves and valve actuation in single And double acting cylinder, and multi actuation circuit.
6	Hydraulic Counterbalancing circuit.
7	Hydraulic or Pneumatic Regenerative circuit.
8	Hydraulic or Pneumatic Sequencing circuit.
9	Circuit with cam operated pilot valves operating a pilot operated 4way direction control Valve or proximity/ limit switches, solenoid operated 4way direction control valve for Auto reversing circuit.
10	Study of hydraulics and Pneumatics circuit, based on the industrial application. (At least one in each)

Reading:

1. Anthony Esposito, "Fluid Power with applications", Pearson edition, 2000.
2. Majumdar S.R., "Oil Hydraulics", Tala McGRaw HILL, 2002.
3. Majumdar S.R., "Pneumatic systems Principles and Maintenance", Tata McGrawHill, New Delhi, 2005.



Channabasaveshwara Institute of Technology

(Affiliated to VTU, Belgaum & Recognized by A.I.C.T.E. New Delhi)

(NAAC Accredited & An ISO 9001:2015 Certified Institution)

NH 206, (B.H. Road), Gubbi, Tumkur – 572 216. Karnataka



DEPARTMENT OF MECHANICAL ENGINEERING.

Course Objectives

1. To provide an insight into the capabilities and applications of hydraulic and pneumatic fluid power.
2. To understand concepts and relationships surrounding force, pressure, energy and power in fluid power systems.
3. To examine concepts centering on sources of hydraulic power, rotary and linear actuators, distribution systems, hydraulic flow in pipes, and control components in fluid powersystems.
4. Exposure to build and interpret hydraulic and pneumatic circuits related to industrial applications.
5. To familiarize with logic controls and trouble shooting.

Course Outcomes

1. Identify and analyse the functional requirements of a fluid power transmission system for a given application.
2. Understand the operation, application, and maintenance of common fluid power components such as pumps, actuators and accumulators.
3. Design an appropriate hydraulic or pneumatic circuit or combination circuit like electro hydraulics, electro pneumatics for a given application.
4. Explain the pneumatic working media, applications and components of pneumatic system.
5. Develop a comprehensive circuit diagram by integrating the components selected for the given application using signal processing element.



Channabasaveshwara Institute of Technology

(Affiliated to VTU, Belgaum & Recognized by A.I.C.T.E. New Delhi)

(NAAC Accredited & An ISO 9001:2015 Certified Institution)

NH 206, (B.H. Road), Gubbi, Tumkur – 572 216. Karnataka



DEPARTMENT OF MECHANICAL ENGINEERING

General Instructions to the Students

- ✓ Laboratory uniform, shoes & safety glasses are compulsory in the lab.
- ✓ Do not touch anything with which you are not completely familiar. Carelessness may not only break the valuable equipment in the lab but may also cause serious injury to you and others in the lab.
- ✓ Please follow instructions precisely as instructed by your supervisor. Do not start the experiment unless your setup is verified & approved by your supervisor.
- ✓ Do not leave the experiments unattended while in progress.
- ✓ Do not crowd around the equipment's & run inside the laboratory.
- ✓ During experiments material may fail and disperse, please wear safety glasses and maintain a safe distance from the experiment.
- ✓ If any part of the equipment fails while being used, report it immediately to your supervisor. Never try to fix the problem yourself because you could further damage the equipment and harm yourself and others in the lab.
- ✓ Keep the work area clear of all materials except those needed for your work and cleanup after your work.



Channabasaveshwara Institute of Technology

(Affiliated to VTU, Belgaum & Recognized by A.I.C.T.E. New Delhi)
(NAAC Accredited & An ISO 9001:2015 Certified Institution)
 NH 206, (B.H. Road), Gubbi, Tumkur – 572 216. Karnataka



DEPARTMENT OF MECHANICAL ENGINEERING

Sl. No.	Particulars	Page No
1	A] Study of Construction and working Hydraulic pumps and Pneumatic. B] Study of Hydraulic and Pneumatic valves. C] Study of solenoid valves, limit switches. Pressure, flow control valve.	01
2	Basic hydraulic circuit for the working of double acting cylinder and a hydraulic motor.	22
3	Basic pneumatic circuit for the working of single and double acting cylinder.	25
4	Speed control circuits. Different Metering methods Inlet & outlet flow control (meter-in & meter-out circuit)	29
5	Circuits for the Use of different direction control valves and valve actuation in single And double acting cylinder, and multi actuation circuit.	32
6	Hydraulic Counter-balancing circuit.	35
7	Hydraulic or Pneumatic Regenerative circuit.	38
8	Hydraulic or Pneumatic Sequencing circuit.	40
9	Circuit with cam operated pilot valves operating a pilot operated 4way direction control Valve or proximity/ limit switches, solenoid operated 4way direction control valve for Auto reversing circuit.	42
10	Study of hydraulics and Pneumatics circuit, based on the industrial application. (At least one in each)	45
14	Viva - Voice	49
15	References	51



Channabasaveshwara Institute of Technology

(Affiliated to VTU, Belgaum & Recognized by A.I.C.T.E. New Delhi)

(NAAC Accredited & An ISO 9001:2015 Certified Institution)

NH 206 (B.H. Road), Gubbi, Tumkur – 572 216. Karnataka.



DEPARTMENT OF MECHANICAL ENGINEERING

LECTURE PLAN

Faculty Name:

Sem. & Sec.: VII 'A'

Sub: H&P LAB

Sub. Code: BME702

Sl.No.	Date	LessonPlan No.	Name of the Experiment	Remarks
1		LP.1	A] Study of Construction and working Hydraulic pumps and Pneumatic valves. B] Study of Hydraulic and Pneumatic valves. C] Study of solenoid valves, limit switches. Pressure, flow control valve	
2		LP.2	Basic hydraulic circuit for the working of double acting cylinder and a hydraulic motor.	
3		LP.3	Basic pneumatic circuit for the working of single and double acting cylinder.	
4		LP.4	Speed control circuits. Different Metering methods Inlet & outlet flow control (meter-in & meter-out circuit)	
5		LP.5	Circuits for the Use of different direction control valves and valve actuation in single And double acting cylinder, and multi actuation circuit.	
6		LP.6	Hydraulic Counter-balancing circuit.	

7		LP.7	Hydraulic or Pneumatic Regenerative circuit.	
8		LP.8	Hydraulic or Pneumatic Sequencing circuit.	
9		LP.9	Circuit with cam operated pilot valves operating a pilot operated 4way direction control Valve or proximity/ limit switches, solenoid operated 4way direction control valve for Auto reversing circuit.	
10.		LP.10	Study of hydraulics and Pneumatics circuit, based on the industrial application. (At least one in each).	

Signature of staff

HOD

EXPERIMENT NO 01**Date:**

- Aim-** A) Study of construction and working Hydraulic pumps, motors and Pneumatic Compressors.
B) Study of hydraulic and pneumatic valves
C) Study of solenoid valve, limits switches.

Theory-**Hydraulic Pumps**

Definition – Pump is the device used to deliver fluid from source to actuators with high pressure.

Classification of pump**A) Rotary pump-**

1. External gear pumps
2. Lobe pumps
3. Internal gear pumps
4. Gerotor pumps

Generally gear pumps are used to pump:

- Petrochemicals: Pure or filled bitumen, pitch, diesel oil, crude oil, lube oil etc.
- Chemicals: Sodium silicate, acids, plastics, mixed chemicals, isocyanates etc.
- Paint and ink
- Resins and adhesives
- Pulp and paper: acid, soap, lye, black liquor, kaolin, lime, latex, sludge etc.

Trapped by the lobes. Fluid travels around the interior of casing in the pockets between the lobes and the casing. Finally,

- Food: Chocolate, cacao butter, fillers, sugar, vegetable fats and oils, molasses, animal food etc.

1. External gear pumps

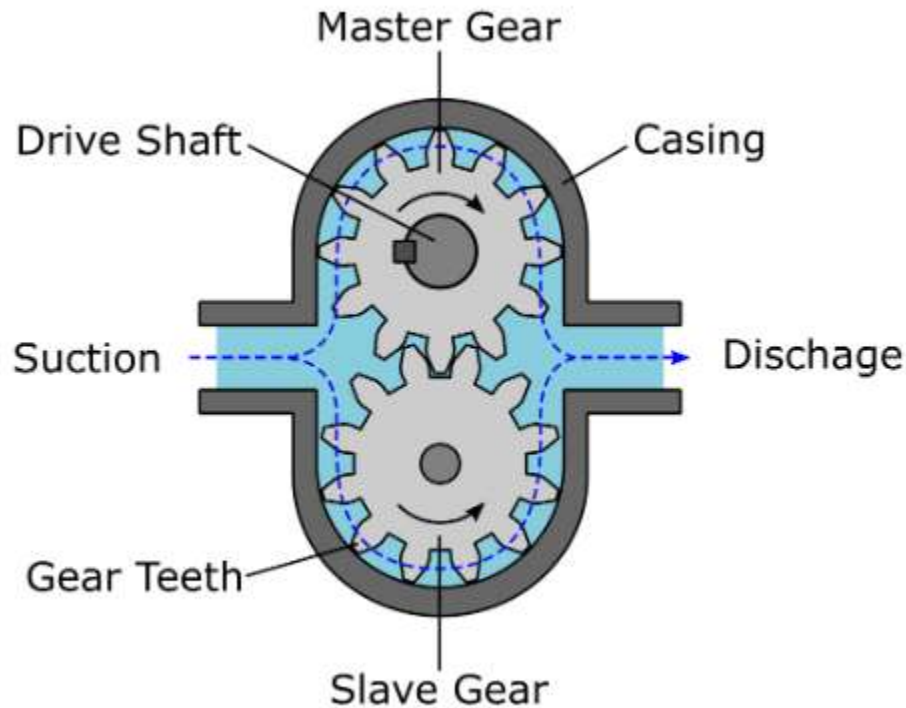

Fig- External gear pump

An external gear pump is a type of positive displacement hydraulic pump commonly used in fluid power systems. It consists of two identical external gears placed side by side inside a close-fitting housing. One of these gears is connected to a power source, such as an electric motor, and is called the driving gear. The other gear, known as the driven gear, rotates due to the meshing action with the driving gear. When the driving gear rotates, it causes the driven gear to rotate in the opposite direction. As the gears rotate, the space between the gear teeth on the inlet side increases, creating a vacuum. This vacuum causes the fluid from the reservoir to enter the pump through the inlet port. The fluid gets trapped in the cavities formed between the gear teeth and the inner walls of the housing. It is then carried along the outer sides of the gears, away from the inlet, toward the outlet. It is important to note that the fluid does not pass between the meshing gear teeth in the center, as the gears mesh tightly and form a seal. At the outlet side, the gear teeth come into mesh again, which reduces the volume between the teeth and pushes the fluid out under pressure through the outlet port. This results in a continuous and steady flow of fluid, making the external gear pump a positive displacement pump. External gear pumps are simple in design, compact in size, and capable of generating moderate pressures. They are widely used in applications such as hydraulic power packs, lubrication systems, and fuel oil circulation. These pumps are especially suitable for transferring high-viscosity fluids.

However, external gear pumps have certain limitations. They produce more noise compared to other types of pumps like vane or internal gear pumps. Additionally, they are not ideal for pumping abrasive or corrosive fluids, as this can lead to wear and damage of the gears and housing. The flow rate of the pump is fixed and depends on the speed of rotation and the size of the gears, which means that flow control must be managed externally if variable output is required.

2. Lobe pumps

The meshing of the lobes forces liquid to pass through the outlet port. The bearings are placed out of the pumped liquid. Therefore the pressure is limited by the bearing location and shaft deflection. Because of superb sanitary qualities, high efficiency, reliability, corrosion resistance and good clean-in-place and steam-in-place (CIP/SIP) characteristics, Lobe pumps are widely used in industries such as pulp and paper, chemical, food, beverage, pharmaceutical and biotechnology etc. These pumps can handle solids (e.g., cherries and olives), slurries, pastes, and a variety of liquids. A gentle pumping action minimizes product degradation. They also offer continuous and intermittent reversible flows. Flow is relatively independent of changes in process pressure and therefore, the output is constant and continuous.

Lobe pumps are frequently used in food applications because they handle solids without damaging the product. Large sized particles can be pumped much effectively than in other positive displacement types. As the lobes do not make any direct contact therefore, the clearance is not as close as in other Positive displacement pumps. This specific design of pump makes it suitable to handle low viscosity fluids with diminished performance. Loading characteristics are not as good as other designs, and suction ability is low. High-viscosity liquids require reduced speeds to achieve satisfactory performance. The reduction in speed can be 25% or more in case of high viscosity fluid.

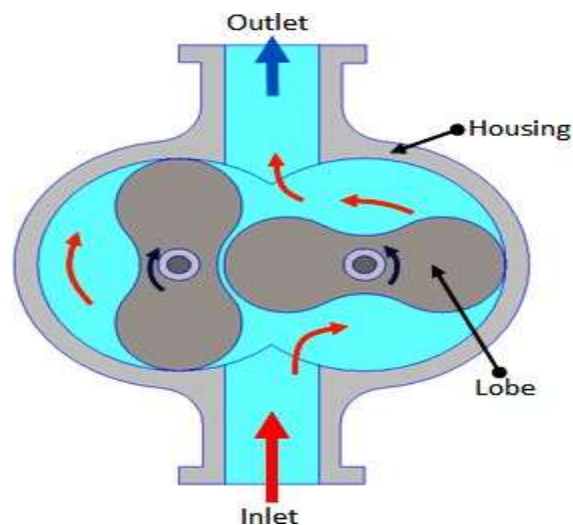

Fig- Lobe pump

3. Internal Gear Pump

Internal gear pumps are exceptionally versatile. They are often used for low or medium viscosity fluids such as solvents and fuel oil and wide range of temperature. This is non-pulsing, self-priming and can run dry for short periods. It is a variation of the basic gear pump.

It comprises of an internal gear, a regular spur gear, a crescent-shaped seal and an external housing. The schematic of internal gear pump is shown in figure. Liquid enters the suction port between the rotor (large exterior gear) and idler (small interior gear) teeth. Liquid travels through the pump between the teeth and crescent. Crescent divides the liquid and acts as a seal between the suction and discharge ports. When the teeth mesh on the side opposite to the crescent seal, the fluid is forced out through the discharge port of the pump. This clearance between gears can be adjusted to accommodate high temperature, to handle high viscosity fluids and to accommodate the wear. These pumps are bi-rotational so that they can be used to load and unload the vessels. As these pumps

have only two moving parts and one stuffing box, therefore they are reliable, simple to operate and easy to maintain. However, these pumps are not suitable for high speed and high pressure applications. Only one bearing is used in the pump therefore overhung load on shaft bearing reduces the life of the bearing.

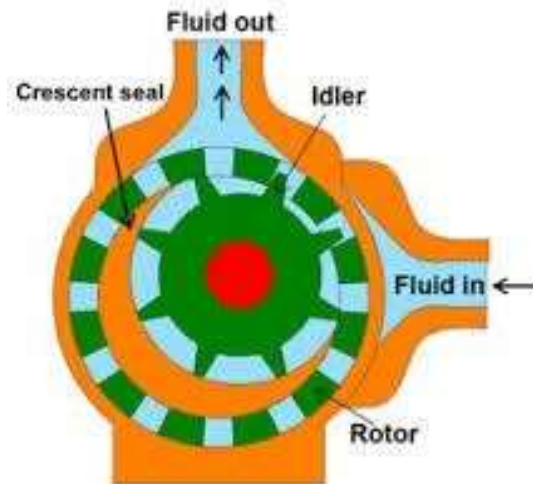

FIG-INTERNAL GEAR PUMP

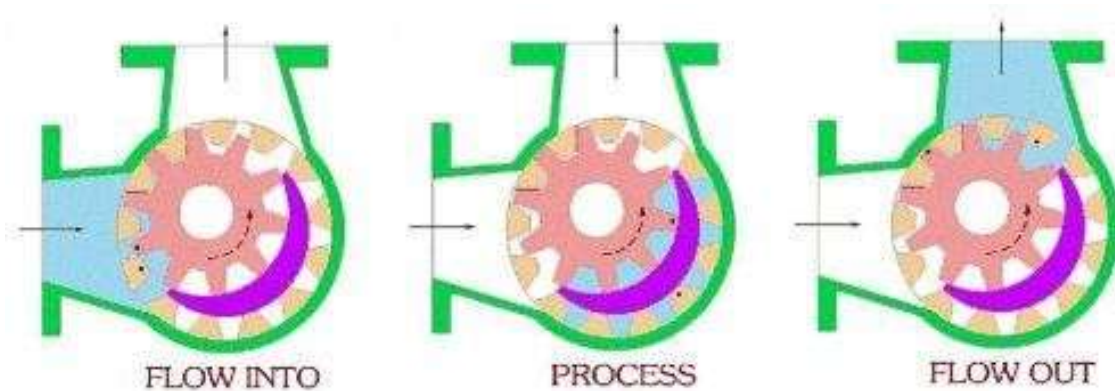

FIG- WORKING OF INTERNAL GEAR PUMP

Applications

Some common internal gear pump applications are:

- All varieties of fuel oil and lube oil
- Resins and Polymers
- Alcohols and solvents
- Asphalt, Bitumen, and Tar
- Polyurethane foam
- Food products such as corn syrup, chocolate, and peanut butter

- Paint, inks, and pigments
- Soaps and surfactants
- Glycol

4. Gerotor Pump

Gerotor is a positive displacement pump. The name Gerotor is derived from "Generated Rotor". At the most basic level, a Gerotor is essentially one that is moved via fluid power. Originally this fluid was water; today the wider use is in hydraulic devices. The schematic of Gerotor pump is shown in figure . Gerotor pump is an internal gear pump without the crescent. It consists of two rotors viz. inner and outer rotor. The inner rotor has N teeth, and the outer rotor has $N+1$ teeth. The inner rotor is located off-center and both rotors rotate. The geometry of the two rotors partitions the volume between them into N different dynamically-changing volumes. During the rotation, volume of each partition changes continuously. Therefore, any given volume first increases, and then decreases. An increase in volume creates vacuum. This vacuum creates suction, and thus, this part of the cycle sucks the fluid. As the volume decreases, compression occurs. During this compression period, fluids can be pumped, or compressed (if they are gaseous fluids).

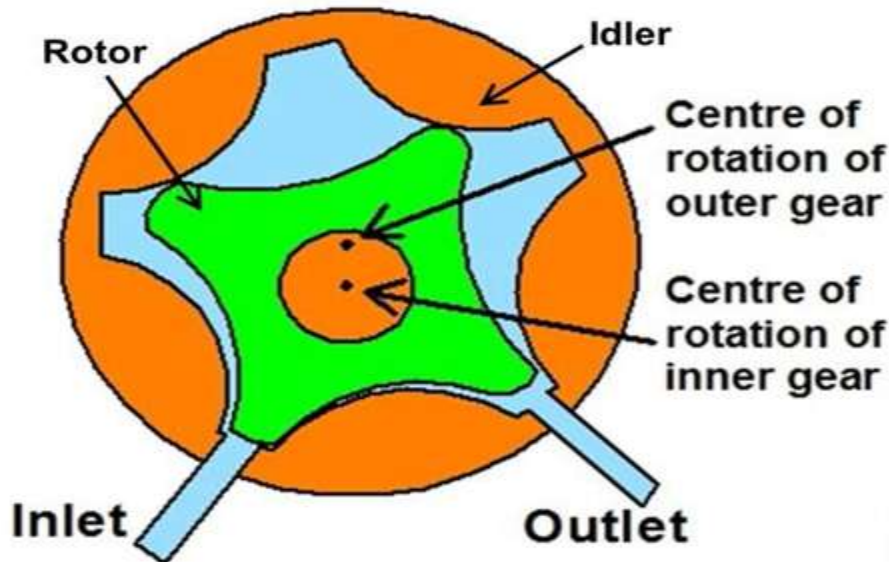

Fig- Working of gerotor pump

The close tolerance between the gears acts as a seal between the suction and discharge ports. Rotor and idler teeth mesh completely to form a seal equidistant from the discharge and suction ports. This seal forces the liquid out of the discharge port. The flow output is uniform and constant at the outlets.

The important advantages of the pumps are high speed operation, constant discharge in all pressure

conditions, bidirectional operation, less sound in running condition and less maintenance due to only two moving parts and one stuffing box etc. However, the pump is having some limitations such as medium pressure operating range, clearance is fixed, solids can't be pumped and overhung load on the shaft bearing etc.

Applications

Gerotors are widely used in industries and are produced in variety of shapes and sizes by a number of different methods. These pumps are primarily suitable for low pressure applications

such as lubrication systems or hot oil filtration systems, but can also be found in low to moderate pressure hydraulic applications. However common applications are as follows:

- Light fuel oils
- Lube oil
- Cooking oils
- Hydraulic fluid

5. Vane Pumps

In the previous lecture we have studied the gear pumps. These pumps have a disadvantage of small leakage due to gap between gear teeth and the pump housing. This limitation is overcome in vane pumps. The leakage is reduced by using spring or hydraulically loaded vanes placed in the slots of driven rotor. Capacity and pressure ratings of a vane pump are generally lower than the gear pumps, but reduced leakage gives an improved volumetric efficiency of around 95%.

Vane pumps are available in a number of vane configurations including sliding vane, flexible vane, swinging vane, rolling vane, and external vane etc. Each type of vane pump has its own advantages. For example, external vane pumps can handle large solids. Flexible vane pumps can handle only the small solids but create good vacuum. Sliding vane pumps can run dry for short periods of time and can handle small amounts of vapor. The vane pumps are known for their dry priming, ease of maintenance, and good suction characteristics. The operating range of these pumps varies from -32 °C to 260 °C.

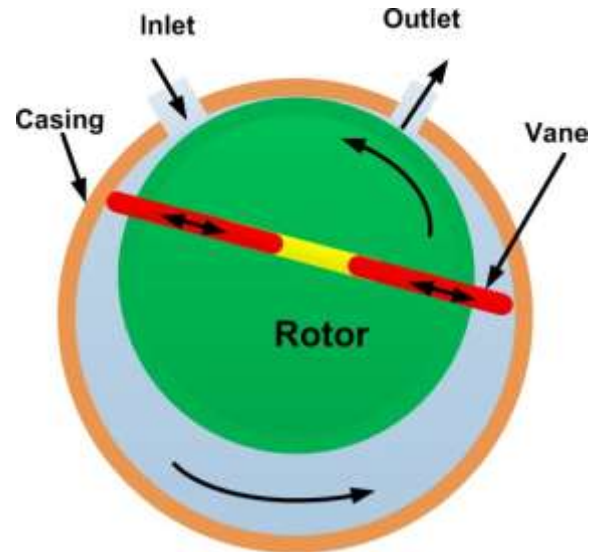

Fig- Vane pump

The schematic of vane pump working principle is shown in figure. Vane pumps generate a pumping action by tracking of vanes along the casing wall. The vane pumps generally consist of a rotor, vanes, ring and a port plate with inlet and outlet ports. The rotor in a vane pump is connected to the prime mover through a shaft. The vanes are located on the slotted rotor. The rotor is eccentrically placed inside a cam ring as shown in the figure. The rotor is sealed into the cam by two side plates. When the prime mover rotates the rotor, the vanes are thrown outward due to centrifugal force. The vanes track along the ring. It provides a tight hydraulic seal to the fluid which is more at the higher rotation speed due to higher centrifugal force. This produces a suction cavity in the ring as the rotor rotates. It creates vacuum at the inlet and therefore, the fluid is pushed into the pump through the inlet. The fluid is carried around to the outlet by the vanes whose retraction causes the fluid to be expelled. The capacity of the pump depends upon the eccentricity, expansion of vanes, width of vanes and speed of the rotor. It can be noted that the fluid flow will not occur when the eccentricity is zero. These pumps can handle thin liquids (low viscosity) at relatively higher pressure. These pumps can be run dry for a small duration without any failure. These pumps develop good vacuum due to negligible leakage. However, these pumps are not suitable for high speed applications and for the high viscosity fluids or fluids carrying some abrasive particles. The maintenance cost is also higher due to many moving parts. These pumps have various applications for the pumping of following fluids:

- Aerosol and Propellants
- Aviation Service - Fuel Transfer, Deicing
- Auto Industry - Fuels, Lubes, Refrigeration Coolants
- Bulk Transfer of LPG and NH₃
- LPG Cylinder Filling
- Alcohols

- Refrigeration - Freons, Ammonia
- Solvents
- Aqueous solutions

6. Unbalanced Vane pump

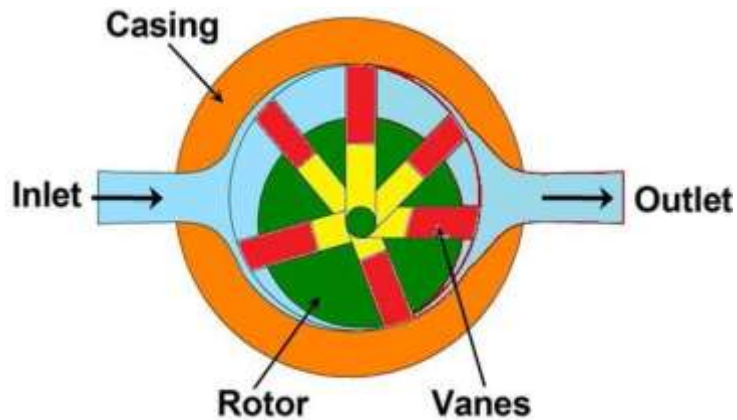

Fig : Unbalanced Vane pump

In practice, the vane pumps have more than one vane as shown in figure. The rotor is offset within the housing, and the vanes are constrained by a cam ring as they cross inlet and outlet ports. Although the vane tips are held against the housing, still a small amount of leakage exists between rotor faces and body sides. Also, the vanes compensate to a large degree for wear at the vane tips or in the housing itself. The pressure difference between outlet and inlet ports creates a large amount of load on the vanes and a significant amount of side load on the rotor shaft which can lead to bearing failure. This type of pump is called as unbalanced vane pump.

B] Piston pumps

Piston pumps are meant for the high-pressure applications. These pumps have high-efficiency and simple design and needs lower maintenance. These pumps convert the rotary motion of the input shaft to the reciprocating motion of the piston. These pumps work similar to the four stroke engines. They work on the principle that a reciprocating piston draws fluid inside the cylinder when the piston retracts in a cylinder bore and discharge the fluid when it extends. Generally, these pumps have fixed inclined plate or variable degree of angle plate known as swash plate when the piston barrel assembly rotates, the swash plate in contact with the piston slippers slides along its surface. The stroke length (axial displacement) depends on the inclination angle of the swash plate. When the swash plate is vertical, the reciprocating motion does not occur and hence

pumping of the fluid does not take place. As the swash plate angle increases, the piston reciprocates inside the cylinder barrel. The stroke length increases with increase in the swash plate angle and therefore volume of pumping fluid increases. During one half of the rotation cycle, the pistons move out of the cylinder barrel and the volume of the barrel increases. During another half of the rotation, the pistons move into the cylinder barrel and the barrel volume decreases. This phenomenon is responsible for drawing the fluid in and pumping it out. These pumps are positive displacement pump and can be used for both liquids and gases. Piston pumps are basically of two types:

i. **Axial piston pumps**

ii. **Radial piston pumps**

1 Axial Piston Pump

Axial piston pumps are positive displacement pumps which converts rotary motion of the input shaft into an axial reciprocating motion of the pistons. These pumps have a number of pistons (usually an odd number) in a circular array within a housing which is commonly referred to as a cylinder block, rotor or barrel. These pumps are used in jet aircraft. They are also used in small earthmoving plants such as skid loader machines. Another use is to drive the screws of torpedoes. In general, these systems have a maximum operating temperature of about 120 °C. Therefore, the leakage between cylinder housing and body block is used for cooling and lubrication of the rotating parts. This cylinder block rotates by an integral shaft aligned with the pistons. These pumps have sub-types as:

a. Bent axis piston pumps

b. Swash plate axial piston pump

Bent-Axis Piston Pumps

Figure shows the schematic of bent axis piston pump. In these pumps, the reciprocating action of the pistons is obtained by bending the axis of the cylinder block. The cylinder block rotates at an angle which is inclined to the drive shaft. The cylinder block is turned by the drive shaft through a universal link. The cylinder block is set at an offset angle with the drive shaft. The cylinder block contains a number of pistons along its periphery. These piston rods are connected with the drive shaft flange by ball-and-socket joints. These pistons are forced in and out of their bores as the distance between the drive shaft flange and the cylinder block changes. A universal link connects the block to the drive shaft, to provide alignment and a positive drive.

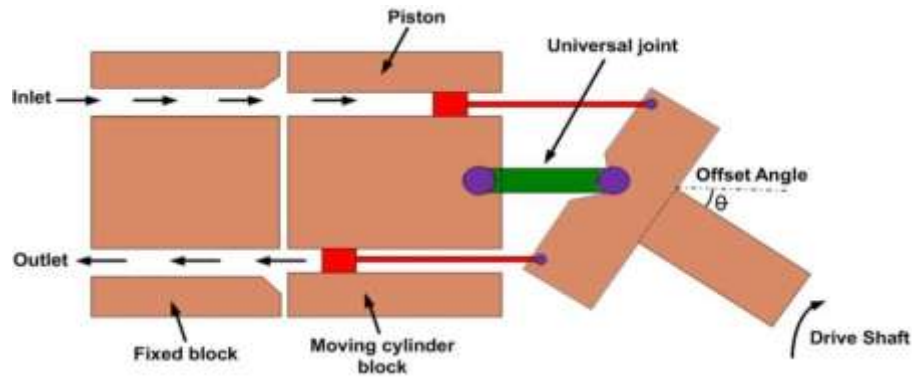

Fig- Bent axis piston pump

The volumetric displacement (discharge) of the pump is controlled by changing the offset angle. It makes the system simple and inexpensive. The discharge does not occur when the cylinder block is parallel to the drive shaft. The offset angle can vary from 0° to 40° . The fixed displacement units are usually provided with 23° or 30° offset angles while the variable displacement units are provided with a yoke and an external control mechanism to change the offset angle. Some designs have arrangement of moving the yoke over the center position to reverse the fluid flow direction. The flow rate of the pump varies with the offset angle. There is no flow when the cylinder block centerline is parallel to the drive shaft centerline (offset angle is 0°).

1.2 Swash Plate Axial Piston Pump

A swash plate is a device that translates the rotary motion of a shaft into the reciprocating motion. It consists of a disk attached to a shaft as shown in Figure. If the disk is aligned perpendicular to the shaft; the disk will turn along with the rotating shaft without any reciprocating effect. Similarly, the edge of the inclined shaft will appear to oscillate along the shaft's length. This apparent linear motion increases with increase in the angle between disk and the shaft (offset angle)

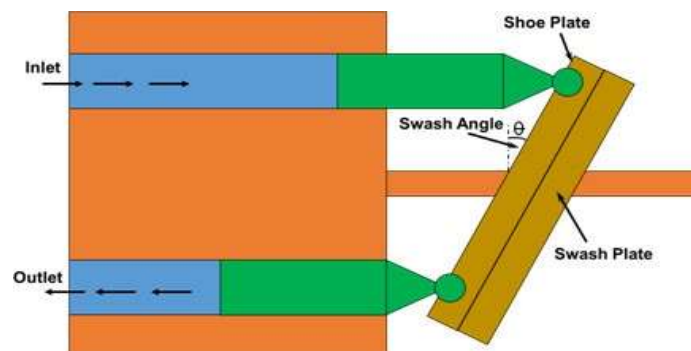

Fig- Swash Plate Piston Pump

In swash plate axial piston pump a series of pistons are aligned coaxially with a shaft through a swash plate to pump a fluid. The schematic of swash plate piston pump is shown in Figure 5.3.6. The axial reciprocating motion of pistons is obtained by a swash plate that is either fixed or has variable degree of angle. As the piston barrel assembly rotates, the piston rotates around the shaft with the piston shoes in contact with the swash plate. The piston shoes follow the angled surface of the swash plate and the rotational motion of the shaft is converted into the reciprocating motion of the pistons. When the swash plate is perpendicular to the shaft; the reciprocating motion to the piston does not occur. As the swash plate angle increases, the piston follows the angle of the swash plate surface and hence it moves in and out of the barrel. The piston moves out of the cylinder barrel during one half of the cycle of rotation thereby generating an increasing volume, while during other half of the rotating cycle, the pistons move into the cylinder barrel generating a decreasing volume. This reciprocating motion of the piston results in the drawing in and pumping out of the fluid. Pump capacity can be controlled by varying the swash plate angle with the help of a separate hydraulic cylinder. The pump capacity (discharge) increases with increase in the swash plate angle and vice-versa. The cylinder block and the drive shaft in this pump are located on the same centerline. The pistons are connected through shoes and a shoe plate that bears against the swash plate. These pumps can be designed to have a variable displacement capability. It can be done by mounting the swash plate in a movable yoke. The swash plate angle can be changed by pivoting the yoke on pointlessly.

2 Radial Piston Pump

The typical construction of radial piston pump is shown in Figure. The piston pump has pistons aligned radially in a cylindrical block. It consists of a pintle, a cylinder barrel with pistons and a rotor containing a reaction ring. The pintle directs the fluid in and out of the cylinder. Pistons are placed in radial bores around the rotor. The piston shoes ride on an eccentric ring which causes them to reciprocate as they rotate. The eccentricity determines the stroke of the pumping piston. Each piston is connected to inlet port when it starts extending while it is connected to the outlet port when start retracting. This connection to the inlet and outlet port is performed by the timed porting arrangement in the pintle. For initiating a pumping action, the reaction ring is moved eccentrically with respect to the pintle or shaft axis. As the cylinder barrel rotates, the pistons on one side travel outward. This draws the fluid in as the cylinder passes the suction port of the pintle. It is continued till the maximum eccentricity is reached. When the piston passes the maximum eccentricity, pintle is forced inwards by the reaction ring. This forces the fluid to flow out of the cylinder and enter in the discharge (outlet) port of the pintle.

The radial piston pump works on high pressure (up to 1000 bar). It is possible to use the pump with various hydraulic fluids like mineral oil, biodegradable oil, HFA (oil in water), HFC (water-glycol), HFD (synthetic ester) or cutting emulsion. This is because the parts are hydrostatically balanced. It makes the pump suitable for the many applications such as machine tools (displace of cutting emulsion, supply for hydraulic equipment like cylinders), high pressure units (overload protection of presses), test rigs, automotive sector (automatic transmission, hydraulic suspension control in upper-class cars), plastic (powder injection molding) and wind energy etc.

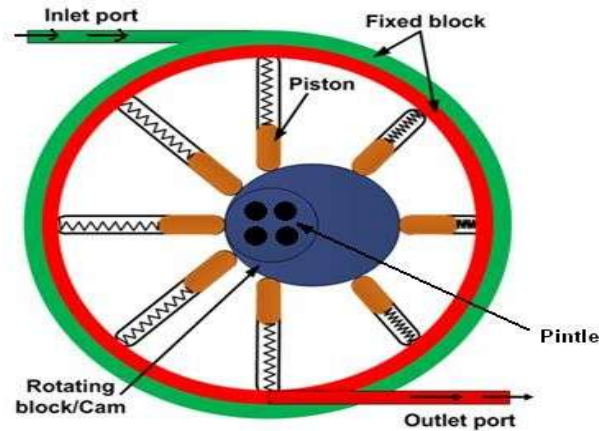

Fig- Radial piston pump

In general the applications of Hydraulic Pumps can be summarized as,

- Hydraulic pumps are used to transfer power via hydraulic liquid. These pumps have a number of applications in automobiles, material handling systems, automatic transmissions, controllers, compressors and household items.
- The hand operated hydraulic pump is used in a hydraulic jack where many strokes of the pump apply hydraulic pressure to lift the ram.
- A backhoe uses an engine driven hydraulic pump to drive the articulating parts of the mechanical hoe.
- The hydraulic pumps are commonly used in the automotive vehicles especially in power steering systems.
- The lift system of tractor is operated by the hydraulic pumps. These are used in automatic transmissions and material handling systems in industries.
- Many precise controllers are developed by using hydraulic pumps. The commonly used compressor is operated by reciprocating pumps.
- The hydraulic pumps are also used in routine household systems like power lift and air-conditions. Therefore, it can be said that the hydraulic pumps have significant applications in industries as well as ones routine life.

Compressor:

It is a mechanical device which converts mechanical energy into fluid energy. The compressor increases the air pressure by reducing its volume which also increases the temperature of the compressed air. The compressor is selected based on the pressure it needs to operate and the delivery volume.

1. Piston compressors

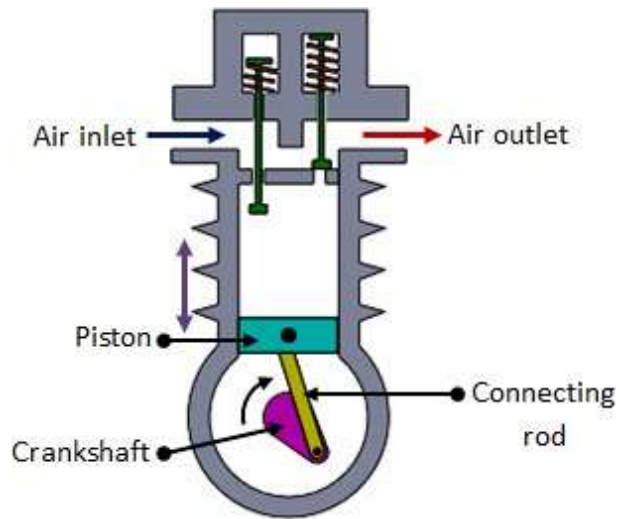

Fig- Piston compressors

Piston compressors are commonly used in pneumatic systems. The simplest form is single cylinder compressor . It produces one pulse of air per piston stroke. As the piston moves down during the inlet stroke the inlet valve opens and air is drawn into the cylinder. As the piston moves up the inlet valve closes and the exhaust valve opens which allows the air to be expelled. The valves are spring loaded. The single cylinder compressor gives significant amount of pressure pulses at the outlet port. The pressure developed is about 3-40 bar.

1 Double acting compressor

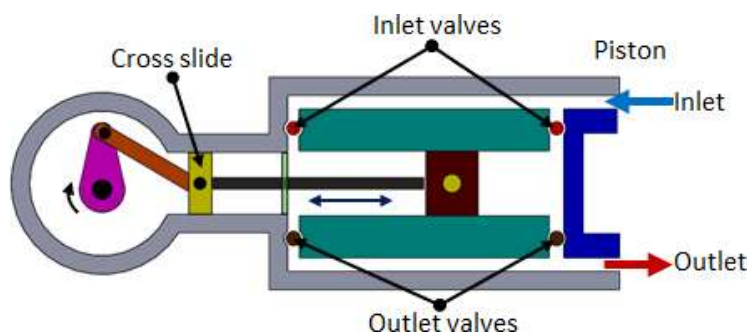

Fig- Double acting compressor

The pulsation of air can be reduced by using double acting compressor as shown in Figure . It has two sets of valves and a crosshead. As the piston moves, the air is compressed on one side whilst on the other side of the piston, the air is sucked in. Due to the reciprocating action of the piston, the air is compressed and delivered twice in one piston stroke. Pressure higher than 30bar can be produced.

2 Multistage compressor

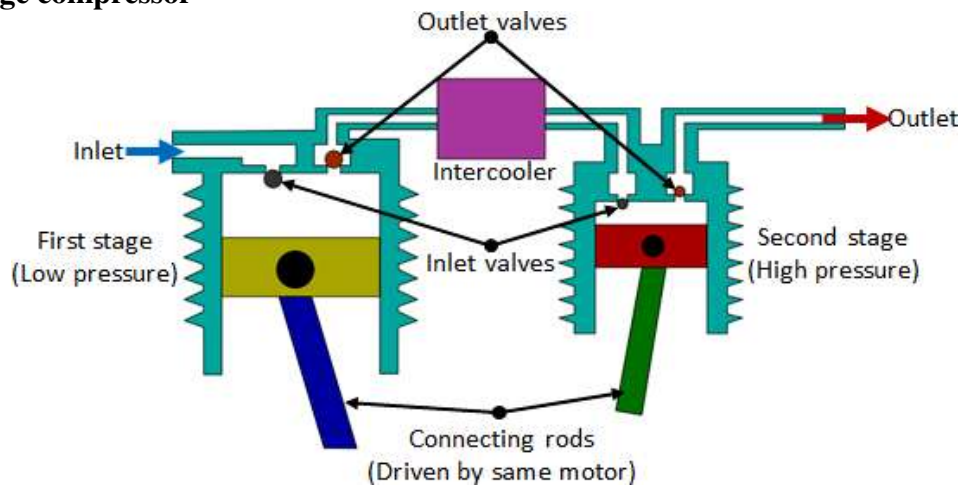

Fig-Multistage compressor

As the pressure of the air increases, its temperature rises. It is essential to reduce the air temperature to avoid damage of compressor and other mechanical elements. The multistage compressor with intercooler in-between is shown in Figure. It is used to reduce the temperature of compressed air during the compression stages. The inter-cooling reduces the volume of air which used to increase due to heat. The compressed air from the first stage enters the intercooler where it is cooled. This air is given as input to the second stage where it is compressed again. The multistage compressor can develop a pressure of around 50bar.

3 Screw compressors

For medium flow and pressure applications, screw compressor can be used. It is simple in construction with less number of moving parts.

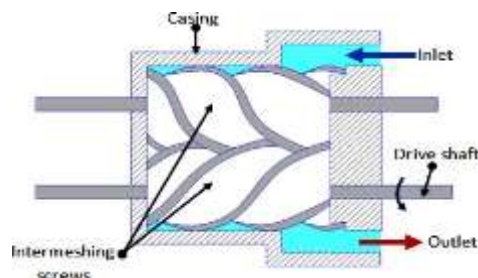

Fig- Screw compressor

The air delivered is steady with no pressure pulsation. It has two meshing screws. The air from the inlet is trapped between the meshing screws and is compressed. The contact between the two meshing surface is minimum, hence no cooling is required. These systems are quite in operation compared to piston type. The screws are synchronized by using external timing gears.

Rotary vane compressors

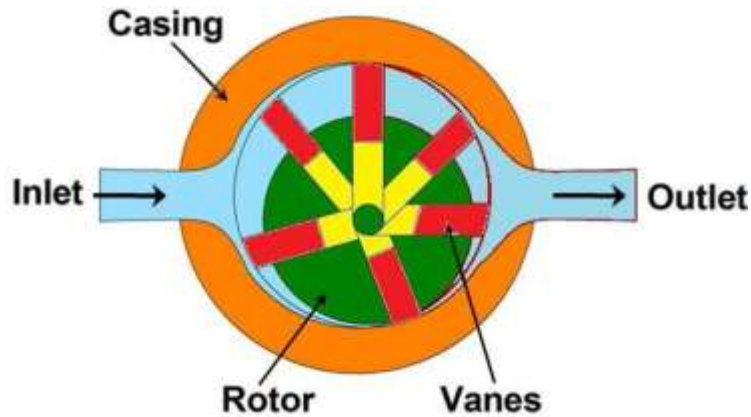

Fig- Vane compressor

The principle of operation of vane compressor is similar to the hydraulic vane pump. Figure shows the working principle of Rotary vane compressor. The unbalanced vane compressor consists of spring loaded vanes seating in the slots of the rotor. The pumping action occurs due to movement of the vanes along a cam ring. The rotor is eccentric to the cam ring. As the rotor rotates, the vanes follow the inner surface of the cam ring. The space between the vanes decreases near the outlet due to the eccentricity. This causes compression of the air. These compressors are free from pulsation. If the eccentricity is zero no flow takes place.

B] Study of hydraulic and pneumatic valves

Pressure Regulation:

flow velocities in pneumatic systems can be quite high, which can lead to significant flow-dependent pressure drops between receiver and load. Therefore, air pressure in the receiver is set higher than

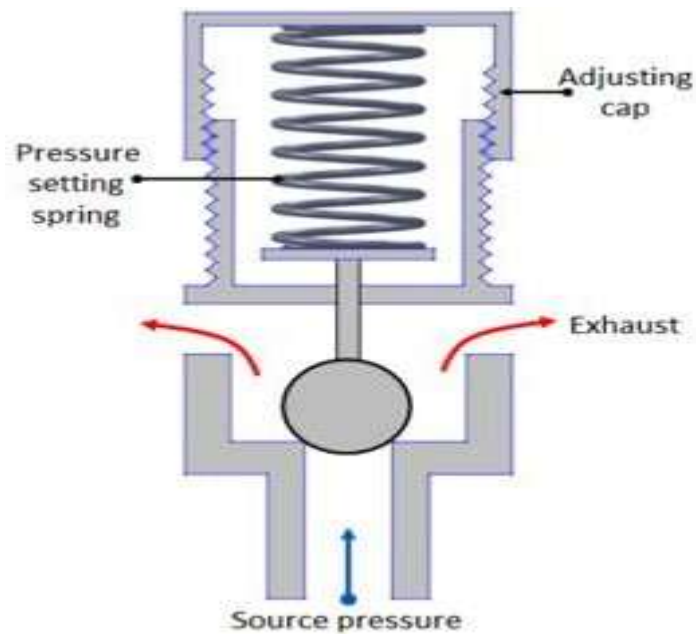
Fig Pressure relief adjusting screw type**Fig.-Rotary relief valve**

Flow control valves - control valve with the pneumatic actuator and smart and positioners. Pneumatically-actuated globe valves and Diaphragm Valves are widely used for control purposes in many industries, although quarter-turn types such as (modified) ball and butterfly valves are also used.

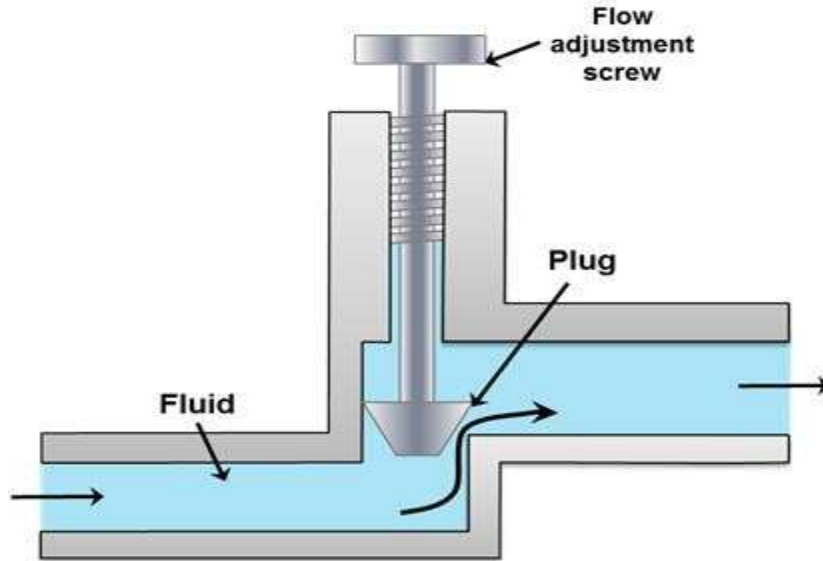

Fig- Flow control valve

Control valves may also work with hydraulic actuators (also known as hydraulic pilots). These types of valves are also known as Automatic Control Valves. The hydraulic actuators will respond to changes of pressure or flow and will open/close the valve. Automatic Control Valves do not require an external power source, meaning that the fluid pressure is enough to open and close the valve.

Automatic control valves include: pressure reducing valves, flow control valves, back-pressure sustaining valves, altitude valves, and relief valves. An altitude valve controls the level of a tank. The altitude valve will remain open while the tank is not full and it will close when the tanks reaches its maximum level. The opening and closing of the valve requires no external power source (electric, pneumatic, or man power), it is done automatically, hence its name.

Applications

Process plants consist of hundreds, or even thousands, of control loops all networked together to produce a product to be offered for sale. Each of these control loops is designed to keep some important process variable such as pressure, flow, level, temperature, etc. within a required operating range to ensure the quality of the end product. Each of these loops receives and internally creates disturbances that detrimentally affect the process variable, and interaction from other loops in the network provides disturbances that influence the process variable To reduce the effect of these load disturbances, sensors and transmitters collect information about the

process variable and its relationship to some desired set point. A controller will then process this information and decides what must be done to get the process variable back to where it should be after a load disturbance occurs. When all the measuring, comparing, and calculating are done, some type of final control element must implement the strategy selected by the controller. The most common final control element in the process control industries is the control valve. The control valve manipulates a flowing fluid, such as gas, steam, water, or chemical compounds, to compensate for the load disturbance and keep the regulated process variable as close as possible to the desired set point.

C] Study of solenoid valves, switches-

A solenoid valve is an electromechanically operated valve. The valve is controlled by an electric current through a solenoid: in the case of a two-port valve the flow is switched on or off; in the case of a three-port valve, the outflow is switched between the two outlet ports. Multiple solenoid valves can be placed together on a manifold.

A solenoid valve has two main parts: the solenoid and the valve. The solenoid converts electrical energy into mechanical energy which, in turn, opens or closes the valve mechanically. A direct acting valve has only a small flow circuit, shown within section E of this diagram (this section is mentioned below as a pilot valve). In this example, a diaphragm piloted valve multiplies this small pilot flow, by using it to control the flow through a much larger orifice.

A-Input side

B-Diaphragm

C-Pressure chamber

D-Pressure relief passage

E-ElectroMechanical Solenoid

F- Output side

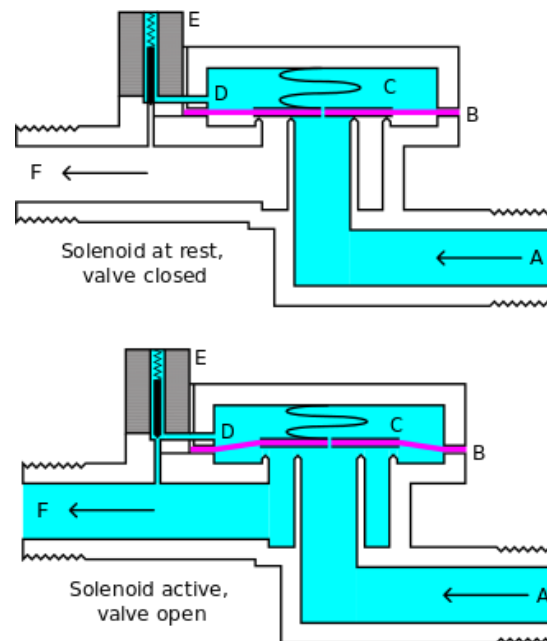

Fig- working of Solenoid valve

The diagram to the shows the design of a basic valve, controlling the flow of water in this example. At the top figure is the valve in its closed state. The water under pressure enters at **A**. **B** is an elastic diaphragm and above it is a weak spring pushing it down. The diaphragm has a pinhole through its center which allows a very small amount of water to flow through it. This water fills the cavity **C** on the other side of the diaphragm so that pressure is equal on both sides of the diaphragm; however the compressed spring supplies a net downward force. The spring is weak and is only able to close the inlet because water pressure is equalized on both sides of the diaphragm.

Once the diaphragm closes the valve, the pressure on the outlet side of its bottom is reduced, and the greater pressure above holds it even more firmly closed. Thus, the spring is irrelevant to holding the valve closed.

The above all works because the small drain passage **D** was blocked by a pin which is the armature of the solenoid **e** and which is pushed down by a spring. If current is passed through the solenoid, the pin is withdrawn via magnetic force, and the water in chamber **C** drains out the passage **D** faster than the pinhole can refill it. The pressure in chamber **C** drops and the incoming pressure lifts the diaphragm, thus opening the main valve. Water now flows directly from **A** to **F**.

When the solenoid is again deactivated and the passage **D** is closed again, the spring needs very little force to push the diaphragm down again and the main valve closes. In practice there is often no separate spring; the elastomer diaphragm is molded so that it functions as its own spring, preferring to be in the closed shape.

From this explanation it can be seen that this type of valve relies on a differential of pressure between input and output as the pressure at the input must always be greater than the pressure at the output for it to work. Should the pressure at the output, for any reason, rise above that of the input then the valve would open regardless of the state of the solenoid and pilot valve.

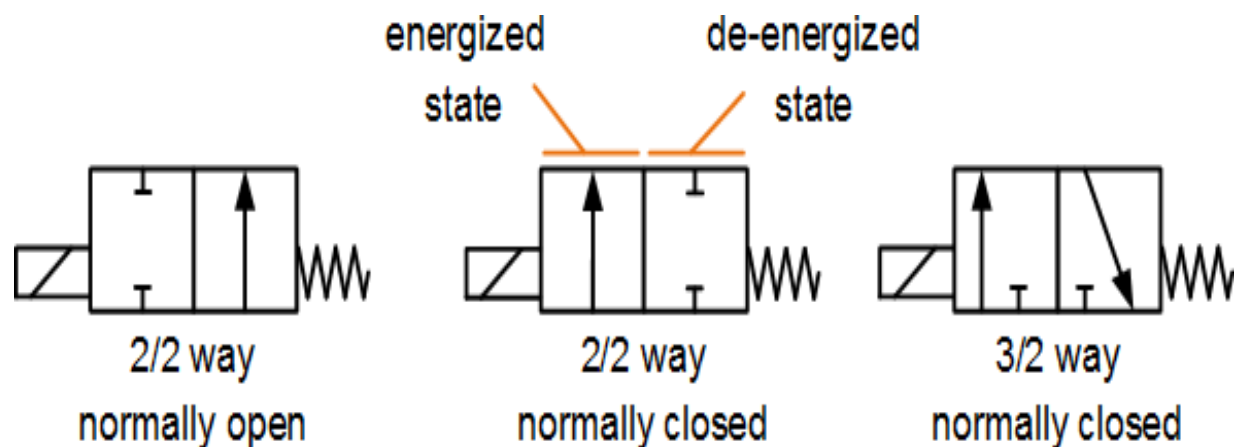

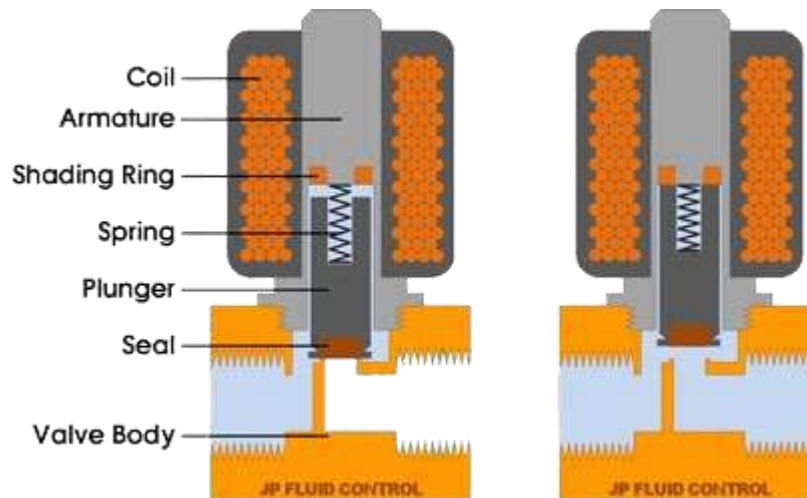
Direct acting solenoid valve-**Fig. direct acting solenoid valve****Direct acting solenoid valve-**

Have the simplest working principle. The medium flows through a small orifice which can be closed off by a plunger with a rubber gasket on the bottom. A small spring holds the plunger down to close the valve. The plunger is made of a ferromagnetic material. An electric coil is positioned around the plunger. As soon as the coil is electrical energized, a magnetic field is created which pulls the plunger up towards the Centre of the coil. This opens the orifice so that the medium can flow through. This is called a Normally Closed (NC) valve. A Normally Open (NO) valve works the opposite way: it has a different construction so that the orifice is open when the solenoid is not powered. When the solenoid is actuated, the orifice will be closed. The maximum operating pressure and the flow rate are directly related to the orifice diameter and the magnetic force of the solenoid valve. This principle is therefore used for relatively small flow rates. Direct operated solenoid valves require no minimum operating pressure or pressure difference, so they can be used from 0 bar up to the maximum allowable pressure. The displayed solenoid valve is a direct operated, normally closed 2/2 way valve.

Limit Switches

Any switch that is actuated due to the position of a fluid power component (usually a piston rod or hydraulic motor shaft or the position of load) is termed as limit switch. The actuation of a limit switch provides an electrical signal that causes an appropriate system response.

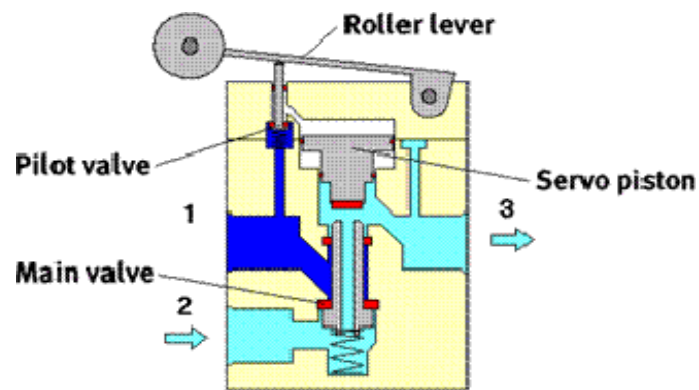

Fig- Working of limit switches

Limit switches perform the same function as push button switches. Push buttons are manually actuated whereas limit switches are mechanically actuated to the eccentricity. This causes compression of the air. These compressors are free from pulsation. If the eccentricity is zero no flow takes place.

Hydraulic hose

There are places on many machines where rigid pipe or tubing cannot be used because of their inflexibility. Rigid lines can cause problems at cylinders with pivot mountings, pumps on noise-isolation mounts, or connections between separate units. Hose avoids these problems.

Observations- To observe the internal and external part of the each equipment, construction and use.

EXPERIMENT-02**Date:**

Aim- Study of Basic hydraulic circuit for the working of double acting cylinder and a hydraulic motor.

Apparatus: - Oil tank, filter, pump, manually operated, 4x3 D.C. valve, double acting cylinder, hoses, hydraulic motor

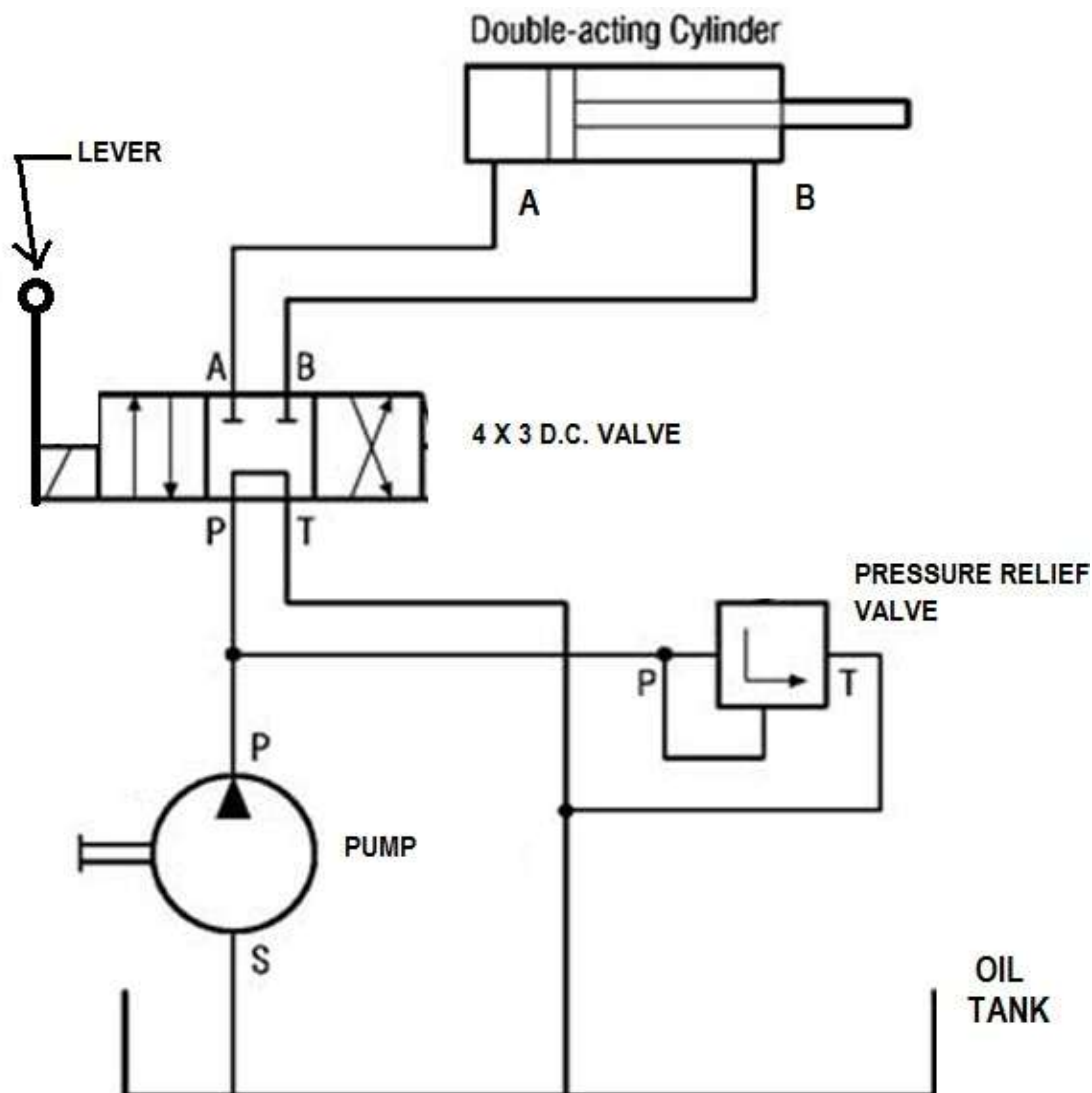

Fig- Basic hydraulic circuit for double acting cylinder

Theory

In this experiments we will see, how the pressure energy of oil converted in mechanical energy by using double acting cylinder, hydraulic motor.

The circuit diagram to control double-acting cylinder is shown in Fig. The control of a double-acting hydraulic cylinder is described as follows:

1 When the 4/3 valve is in its neutral position (tandem design), the cylinder is hydraulically locked and the pump is unloaded back to the tank.

2 When the 4/3 valve is actuated into the flow path, the cylinder is extended against its load as oil flows from port P through port A. Oil in the rod end of the cylinder is free to flow back to the tank through the four-way valve from port B through port T.

3 When the 4/3 valve is actuated into the right-envelope configuration, the cylinder retracts as oil flows from port P through port B. Oil in the blank end is returned to the tank via the flow path from port A to port T.

At the ends of the stroke, there is no system demand for oil. Thus, the pump flow goes through the relief valve at its pressure level setting unless the four-way valve is deactivated.

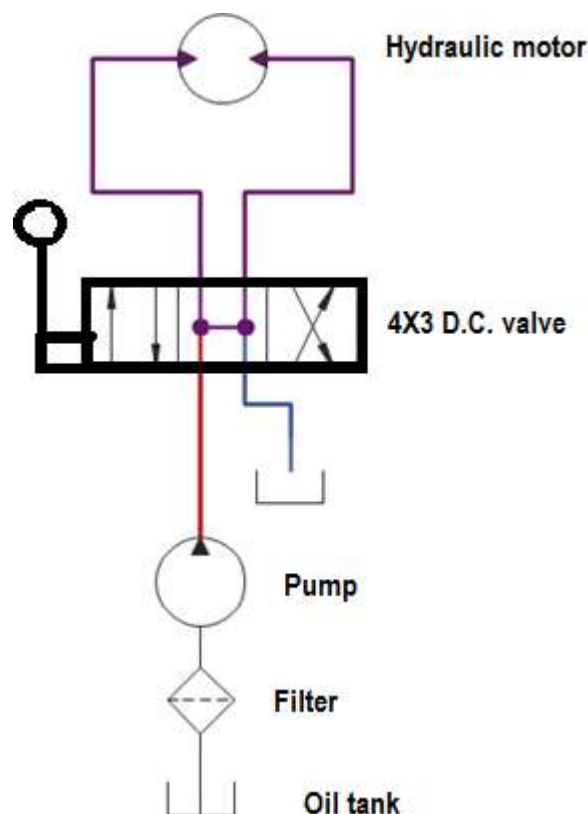

Fig- Working of double acting cylinder and hydraulic motor

Connections

- 1 When the 4/3 valve is in its neutral position (tandem design), the hydraulic motor is hydraulically locked and the pump is unloaded back to the tank.
- 2 When the 4/3 valve is actuated into the flow path, the hydraulic motor is rotates clockwise direction against its load as oil flows from port P through port A. Oil in the hydraulic motor is free to flow back to the tank through the four-way valve from port B through port T.
- 3 When the 4/3 valve is actuated into the right-envelope configuration, the motor rotates anticlockwise direction as oil flows from port P through port B. Oil in the blank end is returned to the tank via the flow path from port A to port T.

Hence we get rotary motion of hydraulic motor in form of mechanical energy

Procedure

- 1] Switch on the three phase connection given to Induction motor
- 2] Rotate pressure relief valve anticlockwise direction for two minutes
- 3] By observing the pressure gauge of pressure line adjust pressure between 12 to 15 kgf/cm²
- 4] Check oil level in tank to be full shown by indicator
- 5] Observe the reciprocating motion of double acting cylinder and hydraulic motor by varying the Pressure, using pressure knob.
- 6] Observe the rotary motion of hydraulic motor.

Observations- Observe the reciprocating motion of double acting cylinder and hydraulic motor by varying the Pressure, using pressure knob.

Applications - Used in for fitting of screw, assemble screwed parts.

EXPERIMENT-03**Date:**

Aim: To Study of Basic pneumatic circuit for the working of single and double acting cylinder

Apparatus: - Air tank, filter, compressor, junction box, manually operated, 2x3 D.C. valve single acting cylinder, double acting cylinder, pipes,

Circuit Diagram:

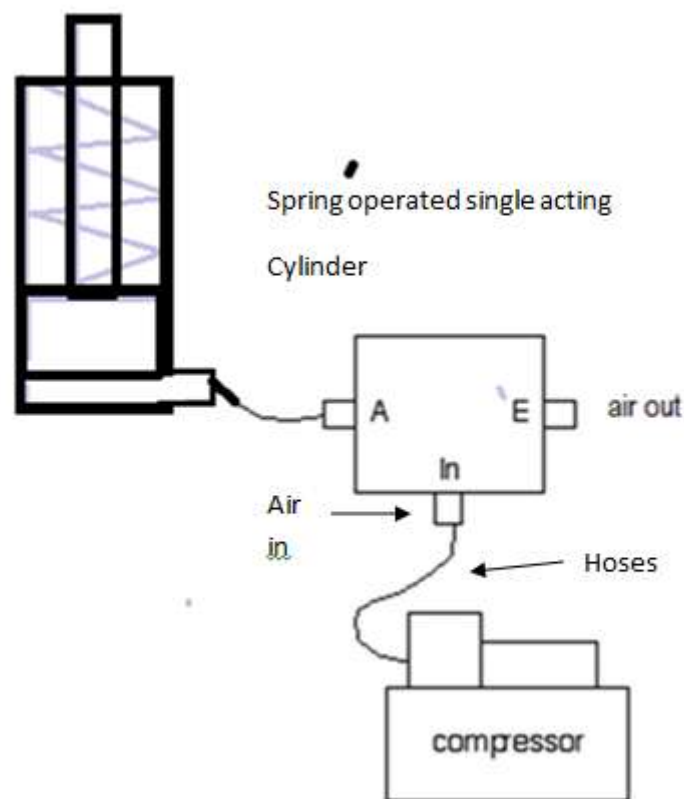

Fig – Schematic sketch Single acting pneumatic cylinder

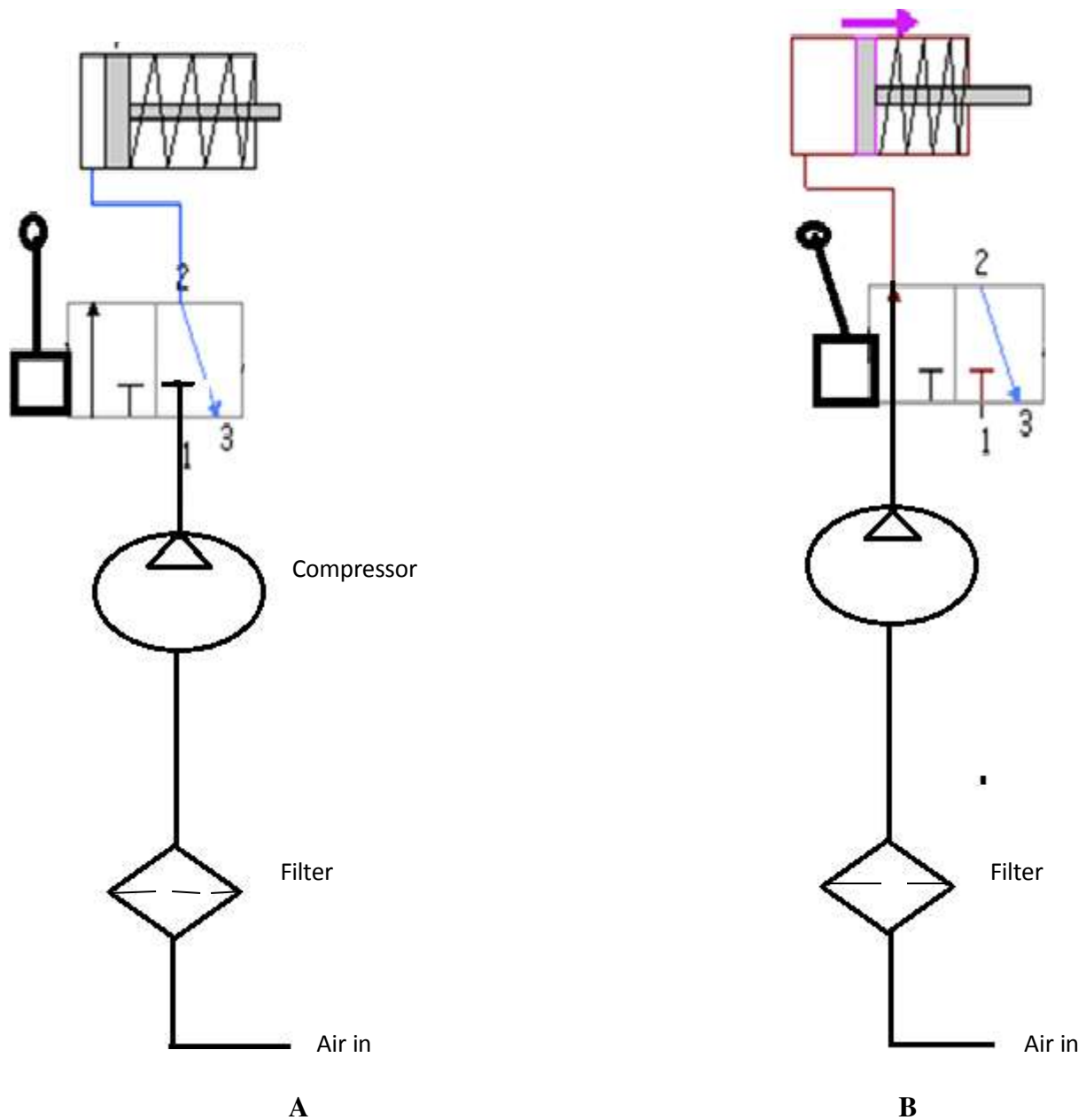

Fig- Working of single acting cylinder operation

Theory

Connect all components as per above shown fig. high pressurized air enters in 3X2 Valve manually forward positions of lever air enters in cylinder,

When lever operated backward the air exhausted in surrounding through port E due to force of compressed spring

Forward motion- Due to pressurized air enters in cylinder.

Backward motion- spring pressure applied on area of piston surface

A] In fig. there is return movement of piston due to spring force. So air is delivered (exhausted) to atmosphere. Here 3x2 direction control valve is used. The air is exhausted to atmosphere through port 2 to 3.

B] In fig. there is forward movement of piston due to high pressure air. So air is entered to cylinder. And apply the force on piston surface Here 3x2 direction control valve is used. The air is entered in cylinder through port 1 to 2.

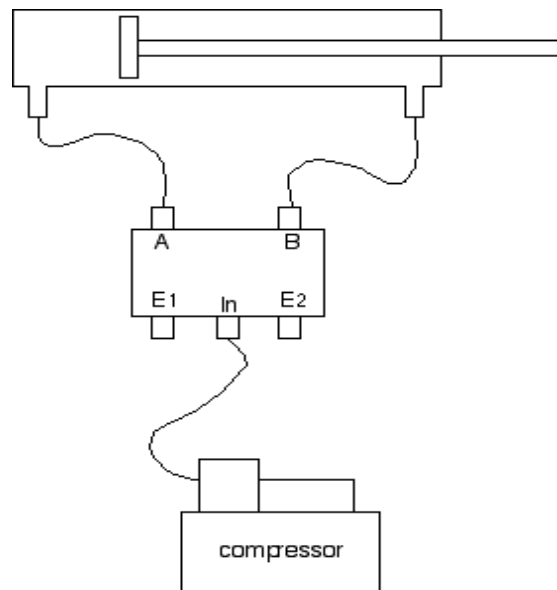
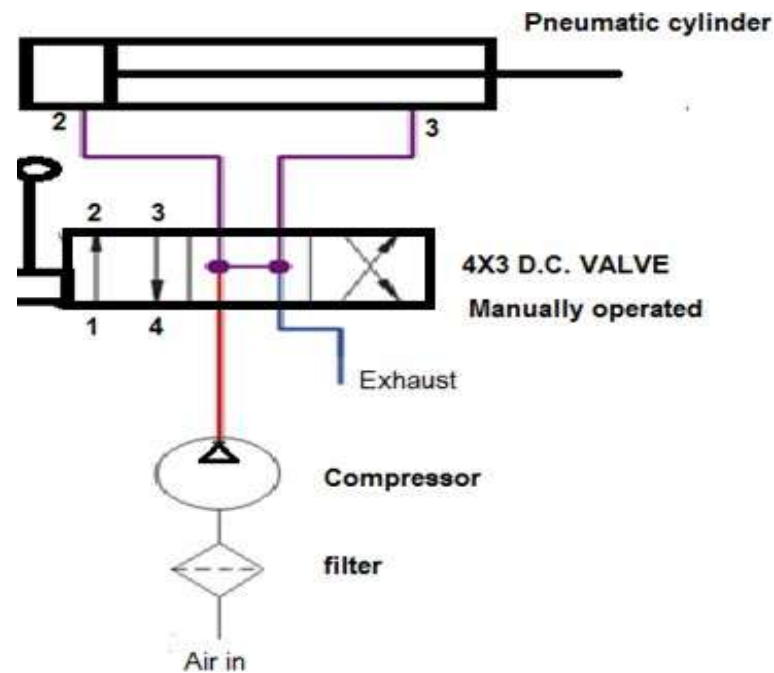

Fig. schematic diagram of double acting pneumatic cylinder



Figures show the working of double acting pneumatic cylinder

Theory:

In above pneumatic circuit we have used 4x3 D.C. valves. The valve is having four ports Port 1 is connected to compressor

Port 3 is relieved to atmosphere through muffler. Port

4 & 2 are connected to pneumatic cylinder

Forward position - At forward movement of piston, port 1 is connected to port 4 and port 2 is connected to port 3

Retract position - At reverse movement of piston, port 1 is connected to port 2 and port 4 is connected to port 3

Procedure

- 1] Switch on the compressor to store high pressure air.
- 2] Connect the pipes as per circuit shown above.
- 3] Connect air reservoir to junction box
- 4] Check pressure level in tank to be full shown by indicator
- 5] Observe the reciprocating motion of Single acting and double acting cylinder.
- 6] Observe the rotary motion of hydraulic motor.

Applications- used in industries for fitting the component of job.

EXPERIMENT-04**Date:**

Aim- Study of Speed control circuits. Different Metering methods Inlet & outlet flow control (meter-in & meter-out circuit)

Apparatus: - Air tank, filter, compressor, junction box, manually operated, 2x3 D.C. valve single acting cylinder, double acting cylinder, pipes,

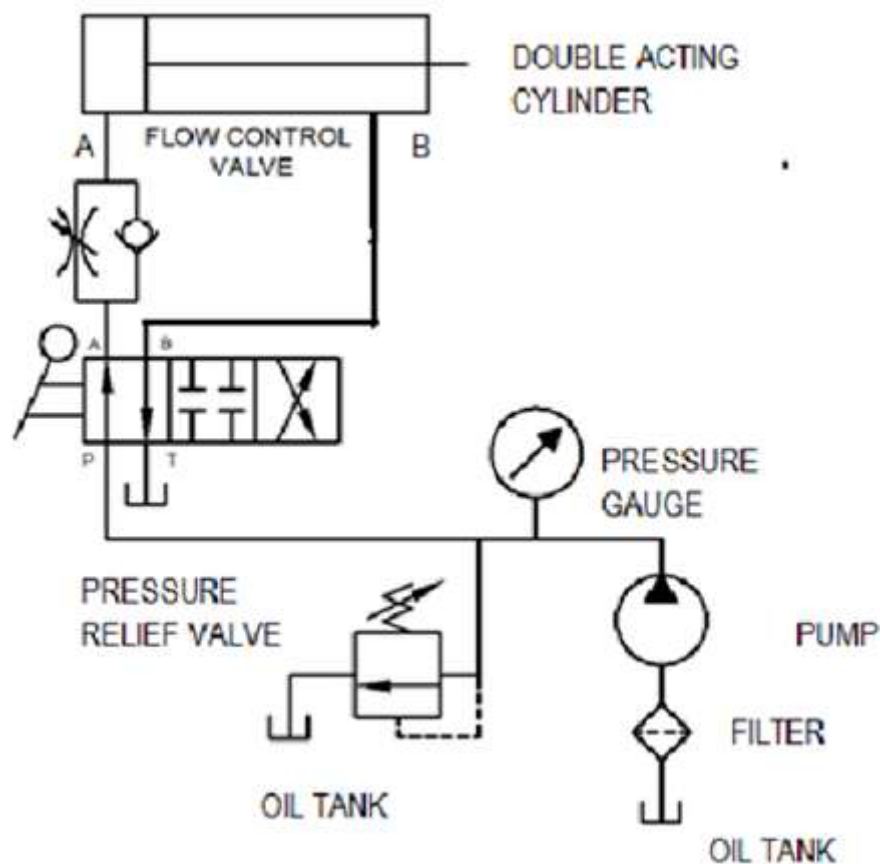

Fig Meter in speed control circuit

Components of Meter in hydraulic circuit- hydraulic cylinder, flow control check valve, 4X3 D.C. valve, pressure relief valve, oil tank, hoses for connections

Procedure

- 1] Switch on the three phase connection given to Induction motor
- 2] Rotate pressure relief valve anticlockwise direction for two minutes
- 3] By observing the pressure gauge of pressure line adjust pressure between 12 to 15 kgf/cm²
- 4] Check oil level in tank to be full shown by indicator

Theory:

The speed control of a hydraulic cylinder circuit can be done during the extension stroke using a flow-control valve (FCV). This is done on a meter-in circuit and meter-out circuit as shown in following figures.

When the Direction Control Valve is actuated, oil flows through the FCV to extend the cylinder. The extending speed of the cylinder depends on the FCV setting.

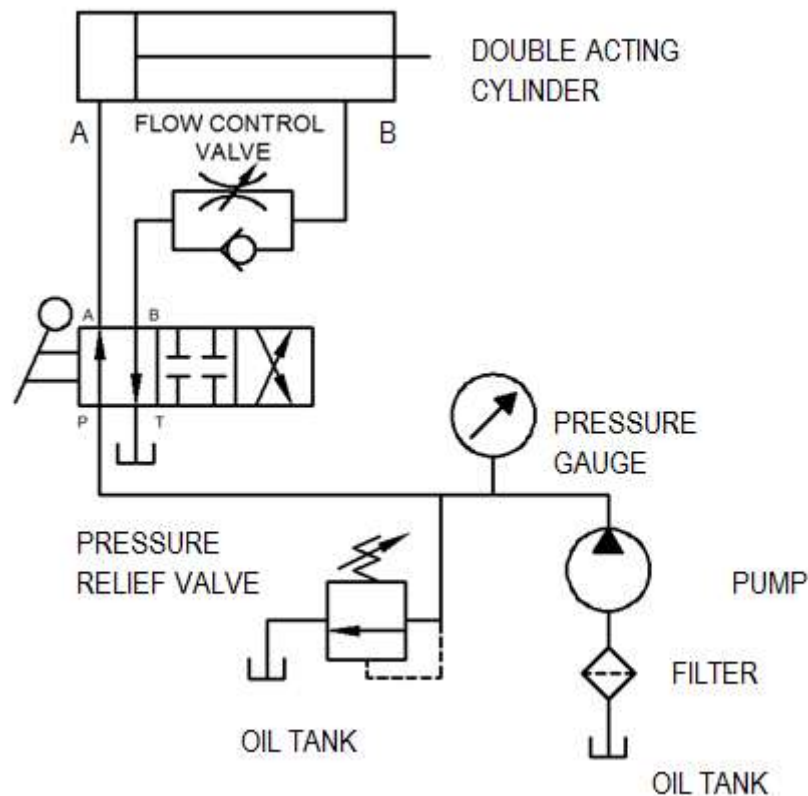

Fig - Meter out speed control circuit

When the DCV is deactivated, the cylinder retracts as oil from the cylinder passes through the check valve. Thus, the retraction speed of a cylinder is not controlled. Figure shows meter-out circuit; when DCV is actuated, oil flows through the rod end to retract the cylinder.

2. Meter-In Versus Meter-Out Flow-Control Valve Systems

FCV is placed in the line leading to the inlet port of the cylinder. Thus, it is called the meter-in

control of speed. Meter-in flow controls the oil flow rate into the cylinder meter-out flow control system is one in which the FCV is placed in the outlet line of the hydraulic cylinder. Thus, a meter-out flow control system controls the oil flow rate out of the cylinder. Meter-in systems are used primarily when the external load opposes the direction of motion of the hydraulic cylinder. When a load is pulled downward due to gravity, a meter-out system is preferred. If a meter-in system is used in this case, the load would drop by pulling the piston rod, even if the FCV is completely closed

One drawback of a meter-out system is the excessive pressure build-up in the rod end of the cylinder while it is extending. In addition, an excessive pressure in the rod end results in a large pressure drop

Applications- Used in shaper tool

EXPERIMENT-05**Date:**

Aim- Study of Circuits for the Use of different direction control valves and valve actuation in single And double acting cylinder, and multi actuation circuit.

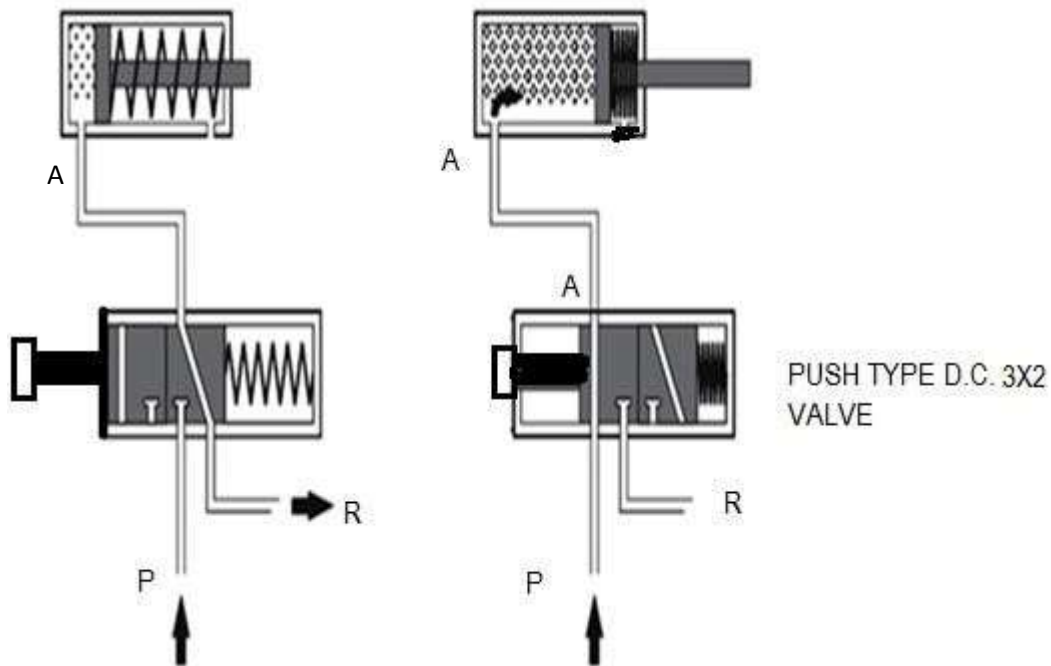

A Fig- Schematic sketch of Directional control valve

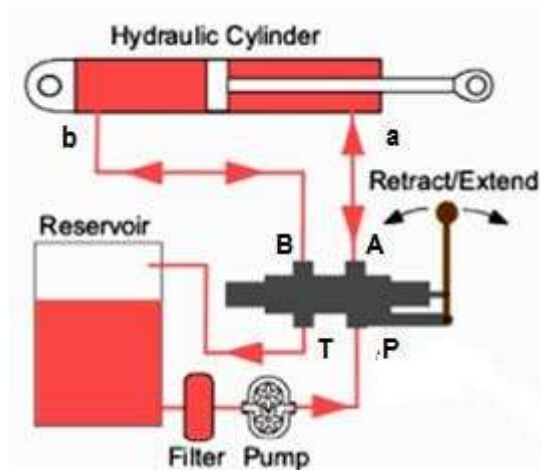

Figures shows the working of Directional control valve

Procedure

- 1] Switch on the three phase connection given to Induction motor
- 2] Rotate pressure relief valve anticlockwise direction for two minutes
- 3] By observing the pressure gauge of pressure line adjust pressure between 12 to 15 kgf/cm²
- 4] Check oil level in tank to be full shown by indicator

Theory:

Schematic diagram shows manually operated hand lever D.C.

Valve. Extend- Right movement of lever

Retract – Left movement of lever

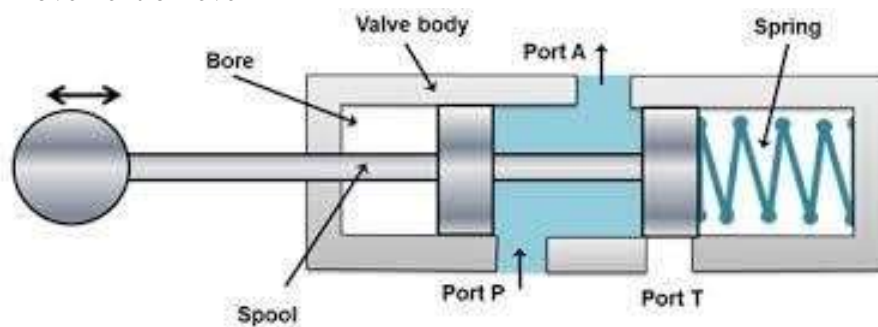

Fig-Manually operated 3X2 D.C. valve

Above fig. shows ball operated three ports two position valve. Here it consists of three ports named P, A & T. It consists of two positions. Above fig. shows normal position in which fluid is flowing port P to port A. When we press the lever towards right direction due to spool present in the valve it closes the flow between port P to port A. Now fluid flowing port A to port T. When we remove the force on lever due to spring force it will get its normal position. It is also called as 3x2 D.C. valves. It is used for working of single acting cylinder in hydraulic circuit.

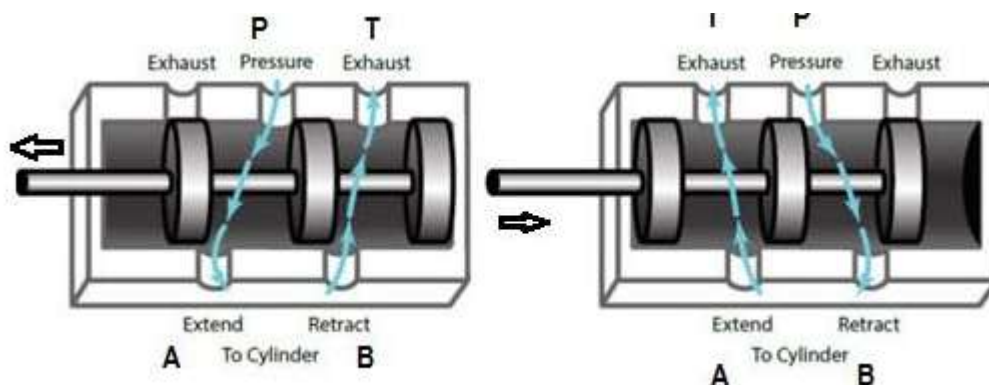

Fig: Spool type 5x2 Valve

Above fig. shows 5x2 direction control valve .In above fig. five ports are shown named exhaust, pressure, exhaust, extend and retract. It consists of three spools in first fig. high pressure air is flowing from pressure port to extend port and retract port to exhaust port. This position is called extending position of piston in double acting pneumatic cylinder. In second fig. it shows retracting position of piston because when we operate the lever of valve the high pressure air is flowing pressure port to retract port and extend port to exhaust.

Applications- used in industries for automation in manufacturing

EXPERIMENT-06

Date:

Aim :- Study of Hydraulic Counter-balancing circuit.

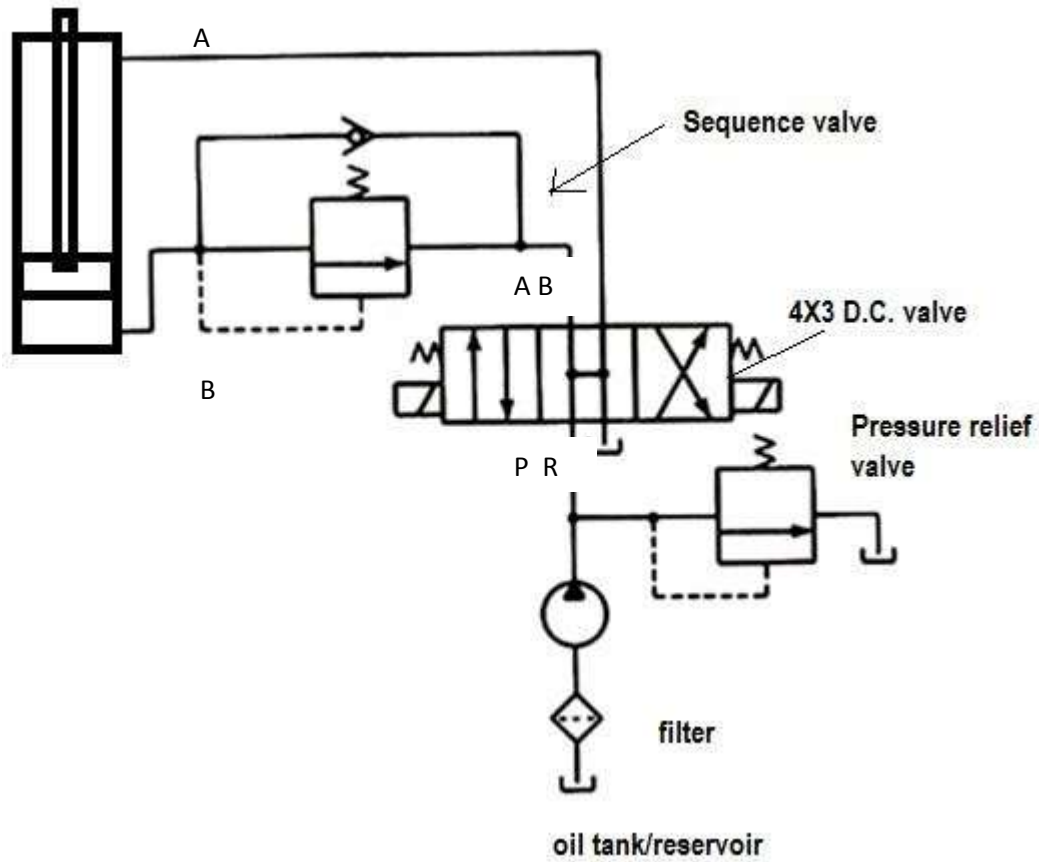
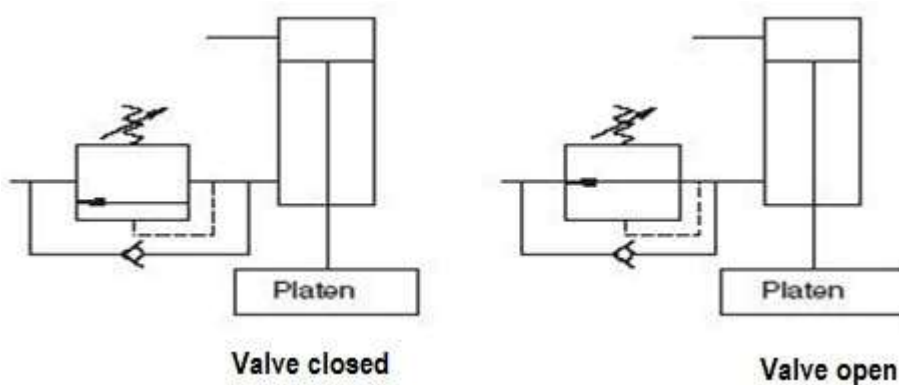

Fig –Working circuit of Counterbalance



Components required: hydraulic cylinder, direction control valve, pump, pressure relief valve, oil tank, Counter balance valve.

Procedure

- 1] Switch on the three phase connection given to Induction motor
- 2] Rotate pressure relief valve anticlockwise direction for two minutes
- 3] By observing the pressure gauge of pressure line adjust pressure between 12 to 15 kgf/cm²
- 4] Check oil level in tank to be full shown by indicator

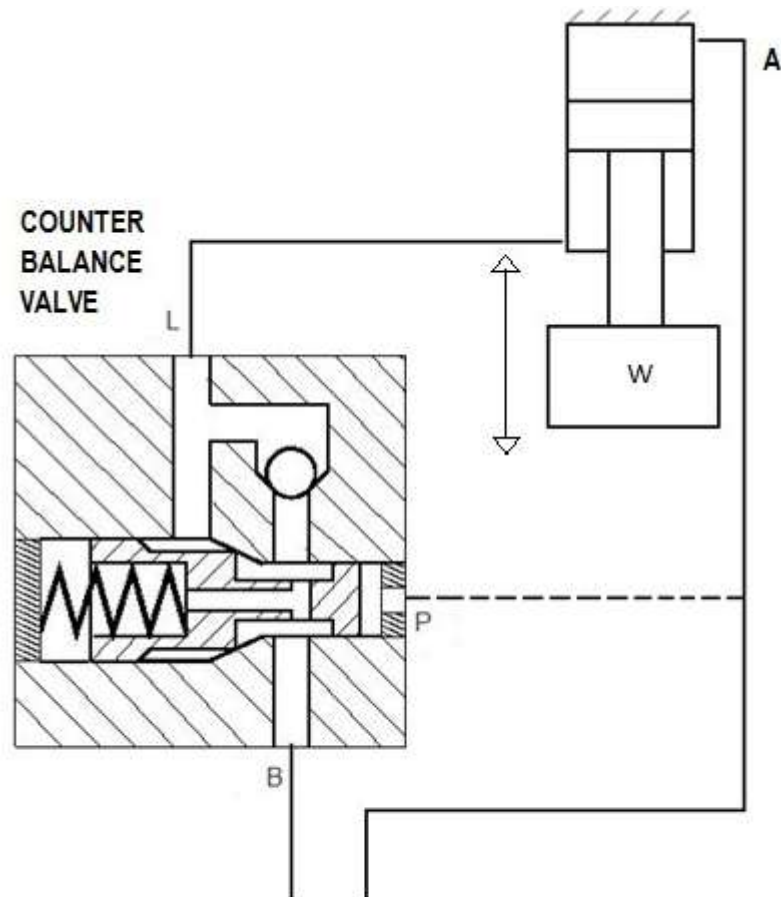

Fig: Counter balance Valve

Theory:

A counterbalance valve is applied to create a back pressure or cushioning pressure on the underside of a vertically moving piston to prevent the suspended load from free falling because of gravity while it is still being lowered.

Valve Operation (Lowering)

The pressure setting on the counterbalance valve is set slightly higher than the pressure required preventing the load from free falling. Due to this back pressure in line A, the actuator piston must force down when the load is being lowered. This causes the pressure in line A to increase, which raises the spring-opposed spool, thus providing a flow path to discharge the exhaust flow from line A to the DCV and then to the tank. The spring-controlled discharge orifice maintains back pressure in line A during the entire downward piston stroke.

Valve Operation (Lifting)

As the valve is normally closed, flow in the reverse direction (from port B to port A) cannot occur without a reverse free-flow check valve. When the load is raised again, the internal check valve opens to permit flow for the retraction of the actuator.

Valve Operation (Suspension)

When the valve is held in suspension, the valve remains closed. Therefore, its pressure setting must be slightly higher than the pressure caused by the load. Spool valves tend to leak internally under pressure.

This makes it advisable to use a pilot-operated check valve in addition to the counterbalance valve if a load must be held in suspension for a prolonged time.

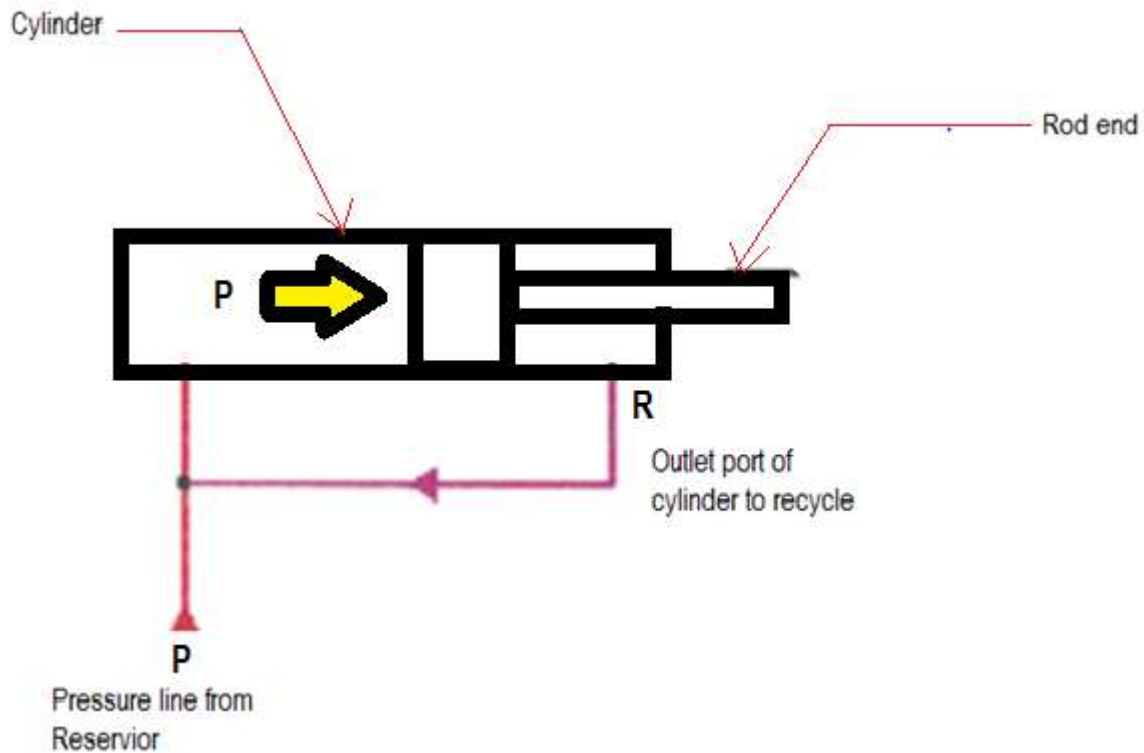
EXPERIMENT-07**Date:****Aim: – Study of Hydraulic or Pneumatic Regenerative circuit.****Fig: Connection of a regenerative**

Components required: hydraulic cylinder, direction control valve, pump, pressure relief valve, oil tank

Figure shows basic concept of a regenerative circuit that is used to speed up the extending speed of a double-acting cylinder.

Procedure

- 1] Switch on the three phase connection given to Induction motor
- 2] Rotate pressure relief valve anticlockwise direction for two minutes
- 3] By observing the pressure gauge of pressure line adjust pressure between 12 to 15 kgf/cm²
- 4] Check oil level in tank to be full shown by indicator

Circuit Theory:

Figure shows a regenerative circuit that is used to speed up the extending speed of a double-acting cylinder. The pipelines to both ends of the hydraulic cylinder are connected in parallel and one of the ports of the 4/3 valve is blocked by simply screwing a thread plug into the port opening. During retraction stroke, the 4/3 valve is configured to the right envelope. During this stroke, the pump flow bypasses the DCV and enters the rod end of the cylinder. Oil from the blank end then drains back to the tank through the DCV.

Applications- used in industries for saving energy required for machining operations.

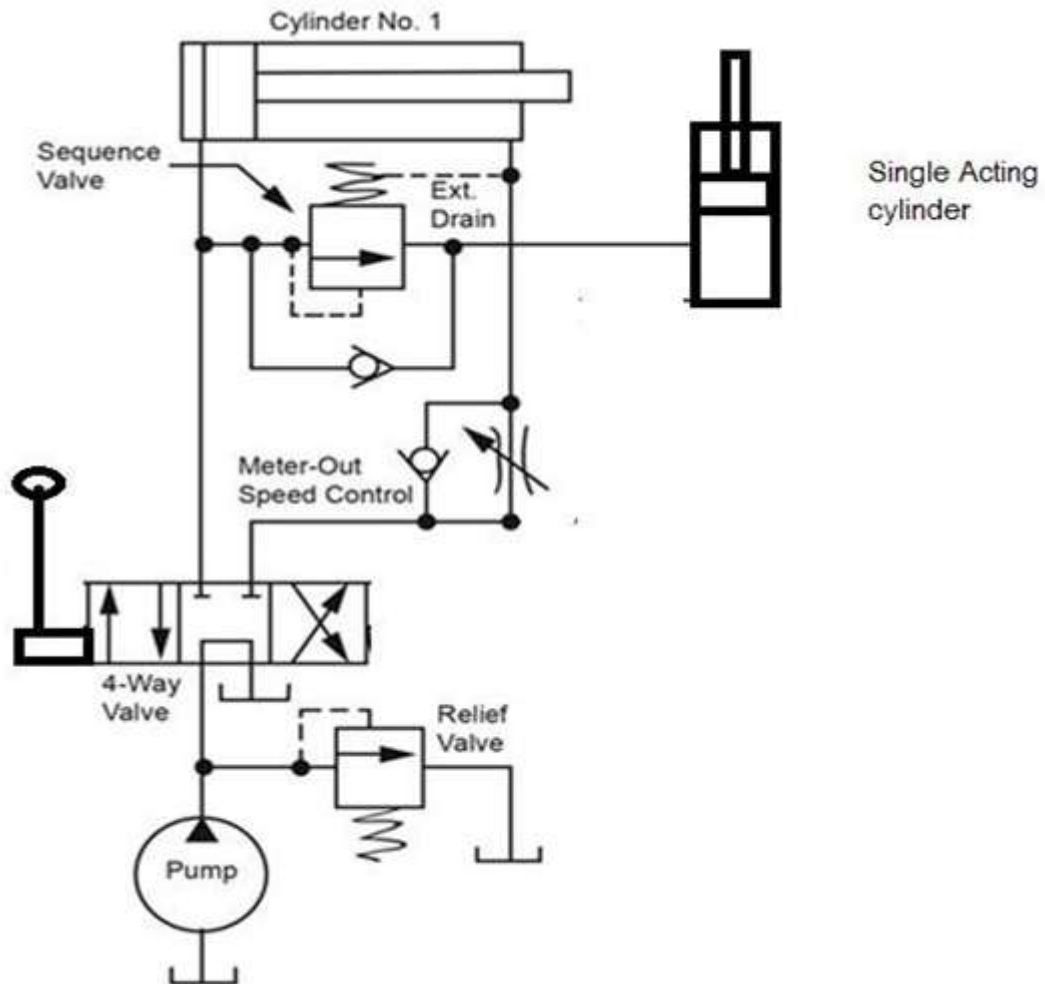
EXPERIMENT-08**Date:****Aim - Study Hydraulic or Pneumatic Sequencing circuit.****Fig. Working Sequencing circuit****Components required-**

Hydraulic cylinders, pump, sequencing valve, 4X3 direction control valve

Hydraulic cylinders can be operated sequentially using a sequence valve.

Procedure

- 1] Switch on the three phase connection given to Induction motor
- 2] Rotate pressure relief valve anticlockwise direction for two minutes
- 3] By observing the pressure gauge of pressure line adjust pressure between 12 to 15 kgf/cm²
- 4] Check oil level in tank to be full shown by indicator.

Theory:

Figure shows that two sequence valves are used to sequence the operation of two double-acting cylinders. When the DCV is actuated to its right-envelope mode, the bending cylinder (B) retracts fully and then the clamp cylinder (A) retracts.

This sequence of cylinder operation is controlled by sequence valves.

Application - This hydraulic circuit can be used in a production operation such as drilling. Cylinder A is used as a clamp cylinder and cylinder B as a drill cylinder. Cylinder A extends and clamps a work piece. Then cylinder B extends to drive a spindle to drill a hole. Cylinder B retracts the drill spindle and then cylinder A retracts to release the work piece for removal

EXPERIMENT-09**Date:**

Aim - Study of Circuit with cam operated pilot valves operating a pilot operated 4way direction control Valve or proximity/ limit switches, solenoid operated 4way direction control valve for Auto reversing circuit.

Procedure

- 1] Switch on the three phase connection given to Induction motor
- 2] Rotate pressure relief valve anticlockwise direction for two minutes
- 3] By observing the pressure gauge of pressure line adjust pressure between 12 to 15 kgf/cm²
- 4] Check oil level in tank to be full shown by indicator

Theory:

Electro pneumatics is now commonly used in many areas of Industrial low cost automation. They are also used extensively in production, assembly, pharmaceutical, chemical and packaging systems. There is a significant change in controls systems. Relays have increasingly been replaced by the programmable logic controllers in order to meet the growing demand for more flexible automation

Electro-pneumatic control consists of electrical control systems operating pneumatic power systems. In this solenoid valves are used as interface between the electrical and pneumatic systems. Devices like limit switches and proximity sensors are used as feedback elements.

Electro Pneumatic control integrates pneumatic and electrical technologies, is more widely used for large applications. In Electro Pneumatics, the signal medium is the electrical signal either AC or DC source is used. Working medium is compressed air. Operating voltages from around 12 V to 220 Volts are often used. The final control valve is activated by solenoid actuation

In Electro pneumatic controls, mainly three important steps are involved:

- **Signal input devices** -Signal generation such as switches and contactor, various types of contact and proximity sensors
- **Signal Processing** – Use of combination of Contactors of Relay or using Programmable Logic Controllers
- **Signal Out puts** – Out puts obtained after processing are used for activation of solenoids,

1.2 SEVEN BASIC ELECTRICAL DEVICES

Seven basic electrical devices commonly used in the control of fluid power systems are

1. Manually actuated push button switches
2. switches
3. Pressure switches
4. Solenoids
5. Relays
6. Timers
7. Temperature switches

Other devices used in electro pneumatics are

1. Proximity sensors
2. Electric counters

2 Limit switches

Any switch that is actuated due to the position of a fluid power component (usually a piston rod or hydraulic motor shaft or the position of load) is termed as limit switch. The actuation of a limit switch provides an electrical signal that causes an appropriate system response.

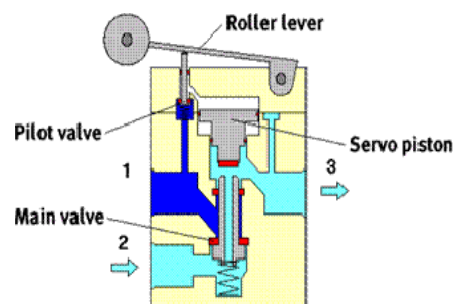

Fig Shows contact type limit switches

Limit switches perform the same function as push button switches. Push buttons are manually actuated whereas limit switches are mechanically actuated

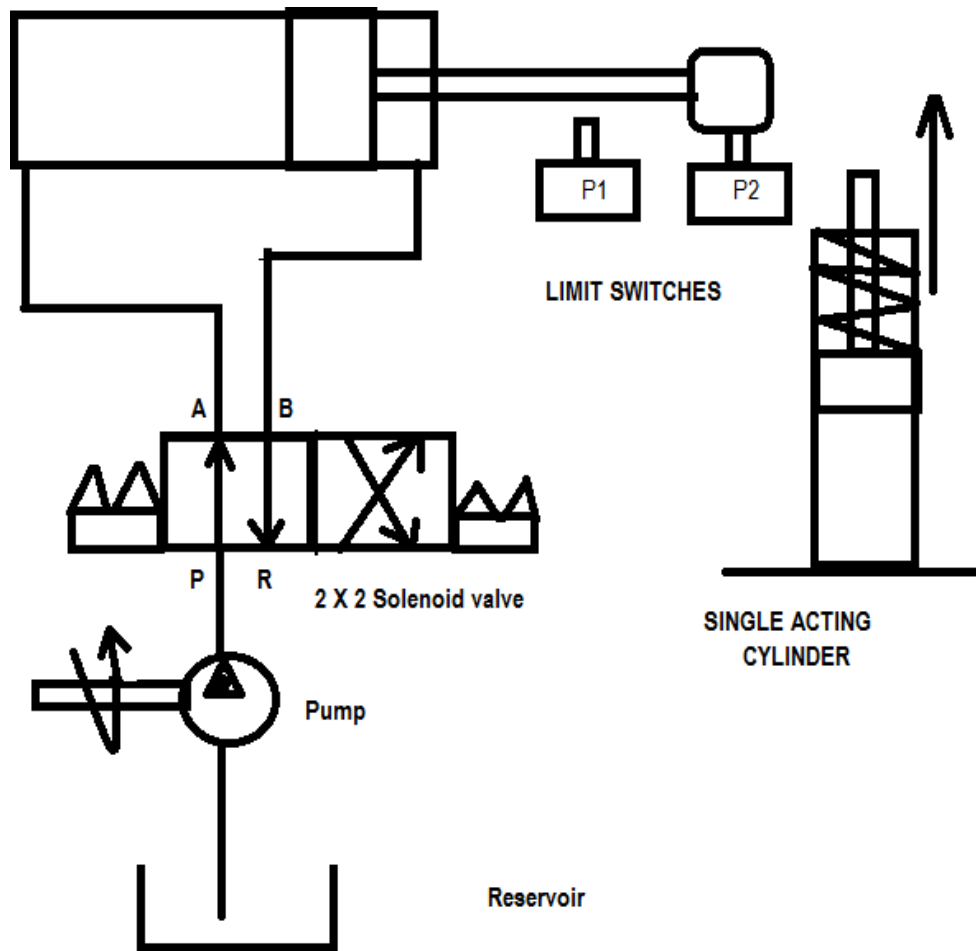
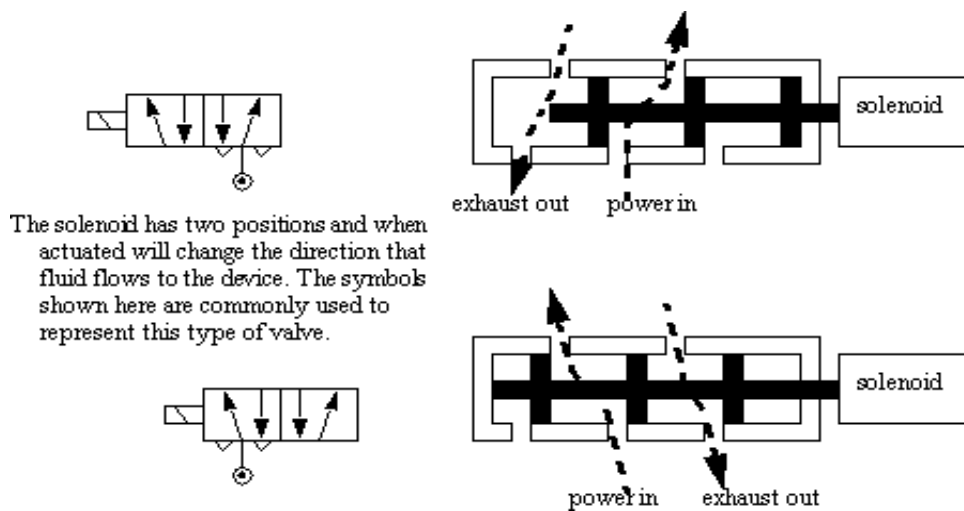

Fig- Working of Solenoid valve



Application - This hydraulic circuit can be used in a production operation clamping, locating such as drilling. Cylinder A is used as a clamp cylinder and cylinder B as a drill cylinder.

EXPERIMENT-10**Date:**

Aim- Study of hydraulics and Pneumatics circuit, based on the industrial

application Theory:**Hydraulic shaping machine**

A shaping machine is also called shaper is mainly used for producing flat surfaces, which may be horizontal, vertical or inclined. Sometimes curved or irregular surfaces are also produced by shapers

In past years, Conventional mechanical shaper machine is used in industries. In this shaper machine gear arrangement is used to give linear motion to the machine tool towards to the work piece. The work piece mounts on a rigid, box shaped table in front of the machine. The height of table can be adjusted suitable to the work piece. In all shaper machine cutting stroke is controlled and return stroke is fast, this can be done by a mechanism which is named as 'Whitworth quick return mechanism'. In conventional shaper machine stroke length can be adjusted by shaper dogs.

In modern era, whole mechanical shaper machine is replaced by hydraulic shaper machine due its ease operation and reliability In this modern shaper machine whole construction is same, but method of actuation is changed. The gear arrangement is totally replaced by a double acting hydraulic cylinder. Hydraulic cylinders are the device which uses hydraulic energy to achieve mechanical movement i.e. linear. A machine tool is used as per application

For example producing v slots v shape tool is used in this hydraulic shaper machine quick return is achieved by placing flow control valve and check valve in return line.

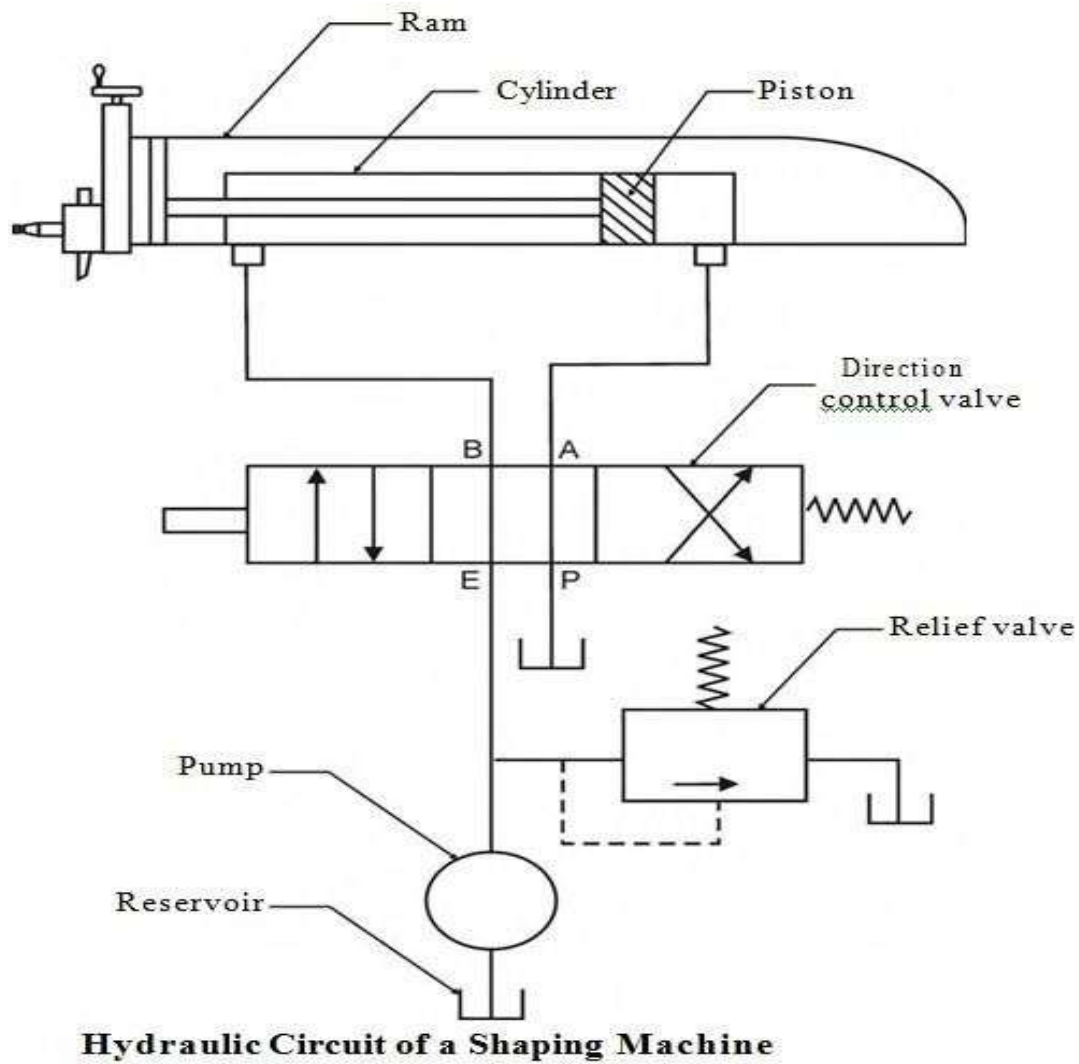

The following component are used for hydraulic shaper machine

In which following parts are used.

Double acting cylinder

4/3 Direction control valve

Pressure relief valve

Filter

Gear pump

Hoses and

fitting

Generally Meter out circuit is used for hydraulic shaper machine. Meter out circuit is as shown in fig below.

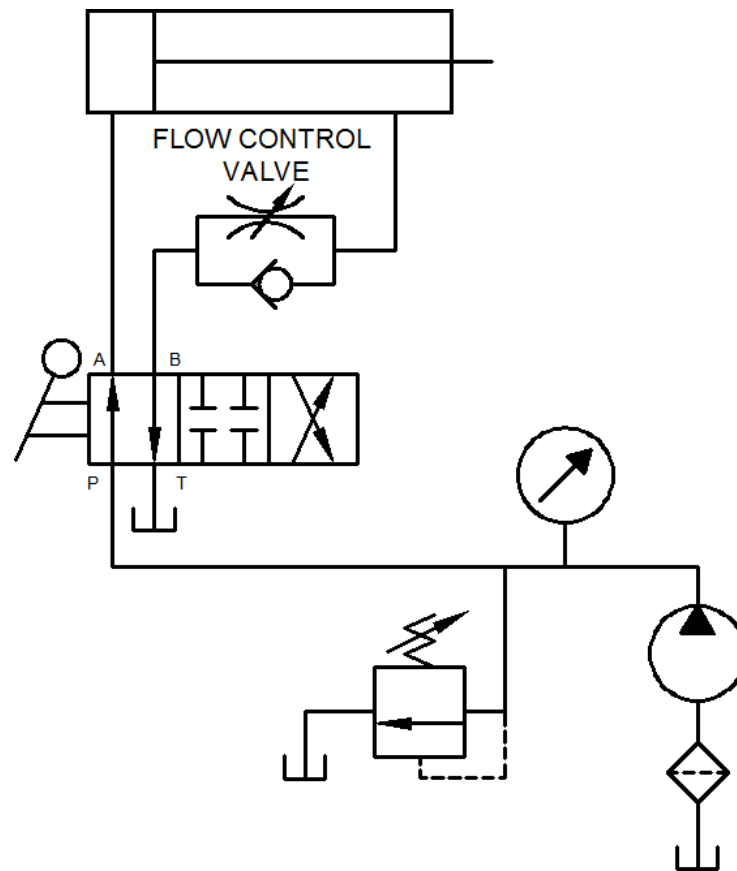

Fig. Meter out circuit for shaping machine

It consists of pneumatic cylinder, compressor, solenoid valve, electric control unit, forging hammer and table.

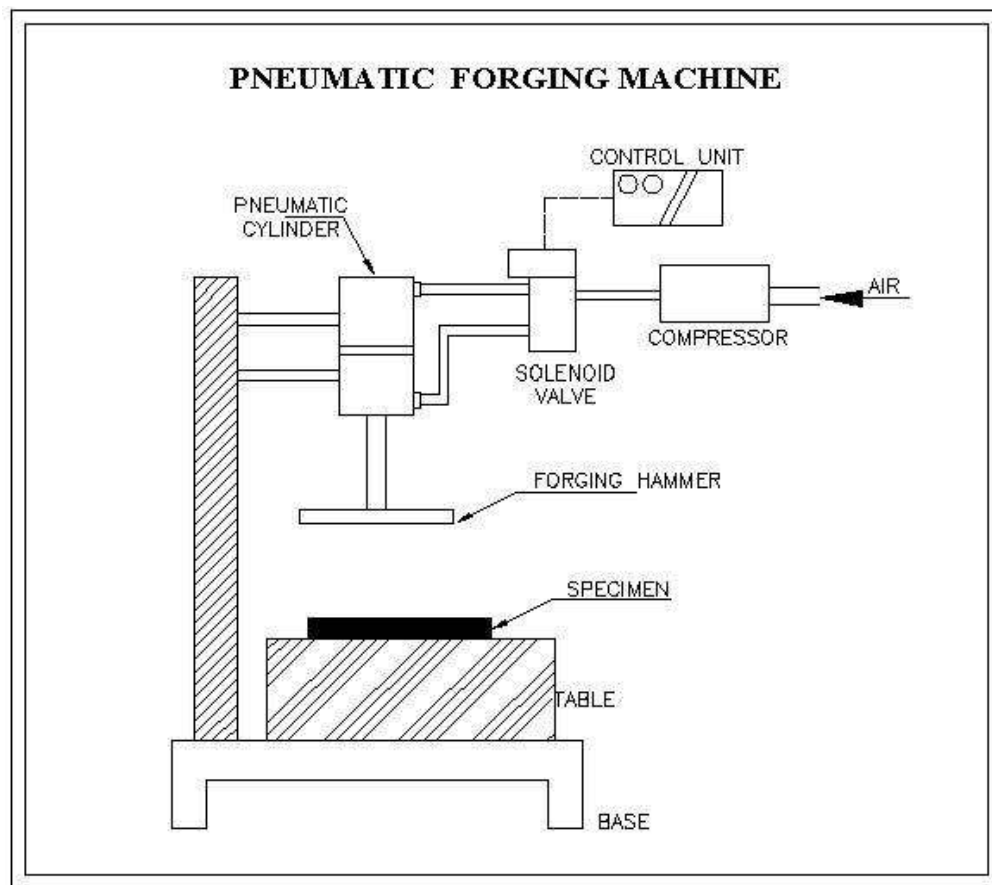

Fig. shows schematic block diagram of pneumatic forging machine.

Air is compressed by compressor, this high pressure air through direction control valve goes inside the pneumatic cylinder causing upward and downward movement of piston.

VIVA QUESTIONS

1. What is the working principle of a hydraulic pump?

A hydraulic pump converts mechanical energy into hydraulic energy by displacing fluid to generate flow, which is then used to do work in the system.

2. Name two types of hydraulic pumps.

Gear pump, Vane pump, and Piston pump.

3. How does a pneumatic pump differ from a hydraulic pump?

A pneumatic pump uses compressed air to generate motion, while a hydraulic pump uses pressurized oil.

Pneumatics operates at lower pressure and are cleaner; hydraulics offer higher force and precision.

4. What is the function of a Direction Control Valve (DCV)?

It controls the direction of flow of the working fluid to various actuators like cylinders or motors.

5. What are the types of DCVs used?

2/2, 3/2, 4/2, 5/2, and 5/3 DCVs.

6. How does a pressure relief valve work?

It protects the system from overpressure by diverting excess fluid when system pressure exceeds a preset value.

7. What is a solenoid valve?

It is an electromechanically operated valve that uses a magnetic coil to open or close the valve.

8. What is the role of a limit switch?

It detects the position of a moving part and sends a signal to stop or change direction of actuators.

9. What is the function of a flow control valve?

It regulates the flow rate of fluid to control the speed of actuators.

10. What is the purpose of a pressure reducing valve?

To maintain a reduced, constant pressure in a part of the system regardless of upstream pressure fluctuations.

11. How does a double-acting hydraulic cylinder work?

Fluid is supplied alternately to both sides of the piston to provide extension and retraction force.

12. What components are used in a hydraulic motor circuit?

Hydraulic motor, DCV, pressure relief valve, reservoir, pump.

13. How is a single-acting cylinder controlled in a pneumatic circuit?

A Compressed air extends the piston, and a spring returns it.

14. What is the use of a 3/2 valve in pneumatics?

It controls a single-acting cylinder with one inlet and one outlet/exhaust.

15. What valve is commonly used with a double-acting cylinder?

A 5/2 or 4/2 DCV is commonly used.

16. What is a meter-in circuit?

It controls the speed by restricting the flow into the actuator.

17. What is a meter-out circuit?

It controls speed by restricting the flow from the actuator to exhaust.

18. What is a regenerative circuit?

A circuit where fluid from the rod end is redirected to the cap end, increasing extension speed.

19. How is a valve actuated in a cylinder circuit?

By mechanical (cam/lever), electrical (solenoid), or pneumatic/pilot methods.

20. What is a multi-actuation circuit?

A circuit that controls multiple actuators with sequencing and coordination.

21. What is a counterbalance valve?

It prevents a load from falling due to gravity by holding back pressure on the return side of an actuator.

22. Where is it used?

In vertical cylinder operations, crane booms, lift tables.

23. What is a sequencing circuit?

A circuit that ensures operations happen in a specific order using sequence valves or limit switches.

24. Give an example.

Cylinder A extends, then cylinder B extends only after A has completed.

25. What is an auto-reversing circuit?

Circuits where a cylinder automatically extends and retracts without manual input using limit switches or pilot signals.

26. How can it be implemented?

Using two limit switches and a solenoid-operated 4/2 DCV or cam-operated pilot valves.

27. Give an example of a hydraulic circuit in industry.

Hydraulic press machine used for sheet metal forming.

28. Give an example of a pneumatic circuit in industry.

A: Pick-and-place unit using pneumatic cylinders and suction cups.

REFERENCES

- John Pippenger, Tyler Hicks, “Industrial Hydraulics”, McGraw Hill International Edition, 1980.
- Andrew Par, Hydraulics and pneumatics, Jaico Publishing House, 2005.
- FESTO, Fundamentals of Pneumatics, Vol I, II and III.
- Herbert E. Merritt, “Hydraulic Control Systems”, John Wiley and Sons, Inc.
- Thomson, Introduction to Fluid power, Prentice Hall, 2004.
- John Watton, “Fundamentals of fluid power control”, Cambridge University press, 2012.